

Fgf8 is required for outgrowth and patterning of the limbs

Anne M. Moon¹ & Mario R. Capecchi²

The expression pattern and activity of fibroblast growth factor-8 (FGF8) in experimental assays indicate that it has important roles in limb development¹⁻³, but early embryonic lethality resulting from mutation of *Fgf8* in the germ line of mice has prevented direct assessment of these roles⁴. Here we report that conditional disruption of *Fgf8* in the forelimb of developing mice bypasses embryonic lethality and reveals a requirement for Fgf8 in the formation of the stylopod, anterior zeugopod and autopod. Lack of Fgf8 in the apical ectodermal ridge (AER) alters expression of other Fgf genes, *Shh* and *Bmp2*. The AER provides signals to maintain mesenchymal cells, in a proliferative state, in the progress zone^{5,6} (PZ) of the limb bud. A favoured model to explain progressive formation of the limb bones postulates that the first cells to leave the PZ form the most proximal element, the stylopod (humerus or femur). Under continued influence of the AER, PZ cells acquire more distal fates and depart the PZ to form the zeugopod and then the autopod⁶.

Exogenous FGF8 can induce ectopic limbs^{3,7-9} and replace the AER to support continued limb development^{2,3,7}. Limb patterning along the anterior-posterior axis requires interaction between the zone of polarizing activity (ZPA) and AER. *Shh*, a proposed mediator of polarizing activity¹⁰, can be induced and maintained by FGF8 in the absence of the AER (refs 3,7). Though other FGFs are expressed in the AER and display similar *in vitro* activities¹⁰⁻¹⁴, it is unknown if they are functionally equivalent *in vivo*.

To directly assess the role of *Fgf8* during mouse limb development, we used gene targeting to generate null and conditional alleles of *Fgf8* (ref. 15). We produced mice bearing a null allele of *Fgf8* (*Fgf8*^{tm1Mrc}, hereafter referred to as *Fgf8*^N; Fig. 1a). No living *Fgf8*^{N/N} mice were detected among progeny of heterozygote intercrosses after embryonic day (E) 9.5 (ref. 4).

The *Fgf8* conditional allele (*Fgf8*^{tm2Mrc}, hereafter *Fgf8*^C) was generated by positioning *loxP* sites within *Fgf8* such that Cre recombinase, when expressed, deletes exon 5, creating a nonfunctional allele (Fig. 1a). To avoid hypomorphic effects resulting from the presence of the neomycin phosphotransferase gene (*neo*^r), the Frt-flanked *neo*^r was removed from this allele by zygote injection of a Flp-recombinase gene¹⁶ (Fig. 1a). *Fgf8*^{C/C} and *Fgf8*^{C/N} mice are born at the expected frequency, have normal limb, craniofacial and cerebellar development, and survive to be fertile adults. The *Fgf8*^C allele expresses the human alkaline phosphatase gene (AP) under control of *Fgf8* regulatory elements following Cre-mediated inactivation of *Fgf8*. This provides a sensitive method for evaluating Cre-mediated excision of *Fgf8*. We generated another conditional allele that retained *neo*^r. Mice homozygous and heterozygous for this allele expressed *Fgf8* in the AER and had normal limbs (Fig. 3b). Although limb development proceeded normally in these animals, this allele is hypomorphic with regard to craniofacial and central nervous system development (Fig. 2b, and data not shown). Because both conditional alleles yielded indistinguishable results with respect to limb development, they were used interchangeably and will be referred to as *Fgf8*^C.

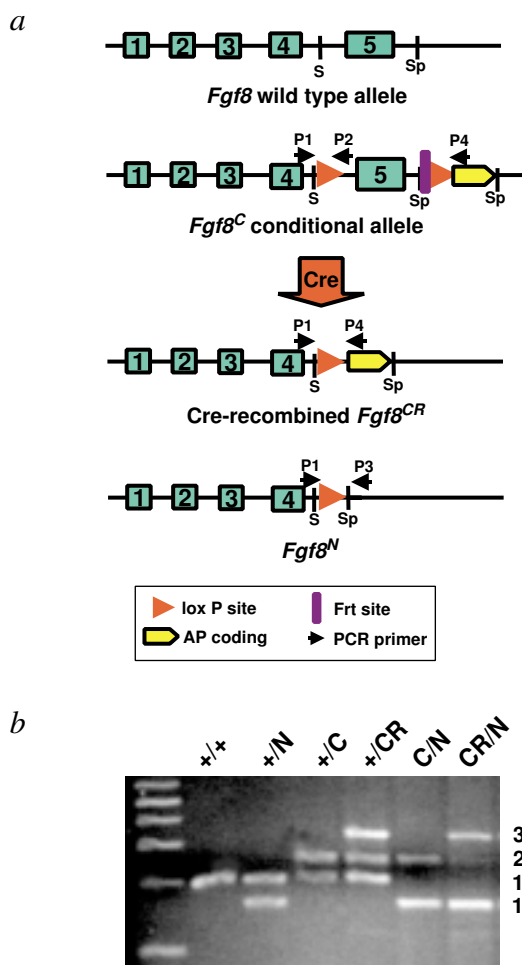

Fig. 1 Targeting the *Fgf8* locus. **a**, The wild-type *Fgf8* locus is depicted on the top line, exons are shown as green boxes and are identified numerically³⁰. *Fgf8*^C targeting vectors were constructed by inserting *loxP* sites in untranslated regions flanking exon 5; Cre-mediated recombination deletes all sequences between the two *loxP* sites and generates the inactive allele, *Fgf8*^{CR}. The 5' *loxP* site (red arrowhead) was inserted into a *Sma*I (S) site, 147 bp 5' of exon 5. A cassette containing frt-flanked pol II/*neo*^r, *loxP* followed by a splice acceptor and coding sequences for human alkaline phosphatase (AP, yellow arrow) was inserted into a *Spe*I (Sp) site, 230 bp downstream of the translation stop. The frt-flanked pol II/*neo*^r gene was subsequently deleted from the *Fgf8*^C allele by exposure to Flp recombinase (leaving a residual Frt site, purple line). Cre-mediated recombination of this AP-containing allele not only inactivates *Fgf8*, but also causes AP to be expressed under control of the *Fgf8* promoter as a reporter of the recombination event in cells in which *Fgf8* is transcribed. The null allele, *Fgf8*^N, was generated by Cre-mediated recombination of a hypomorphic conditional allele (not shown) in the germ line. **b**, Genotyping was performed by PCR analysis on DNA prepared from yolk sacs or tails using the primers shown in (a) (black arrowheads). P1 and P2 distinguish the wild-type (194 bp) and *Fgf8*^C (246 bp) alleles. The product amplified with P1 and P3 from the *Fgf8*^N allele is 149 bp, whereas that amplified using P1 and P4 from the *Fgf8*^{CR} allele is 355 bp.

¹Departments of Pediatrics and Human Molecular Biology and Genetics, and ²Howard Hughes Medical Institute and Department of Human Genetics, University of Utah School of Medicine, Salt Lake City, Utah, USA. Correspondence should be addressed to M.R.C. (e-mail: mario.capecchi@genetics.utah.edu).

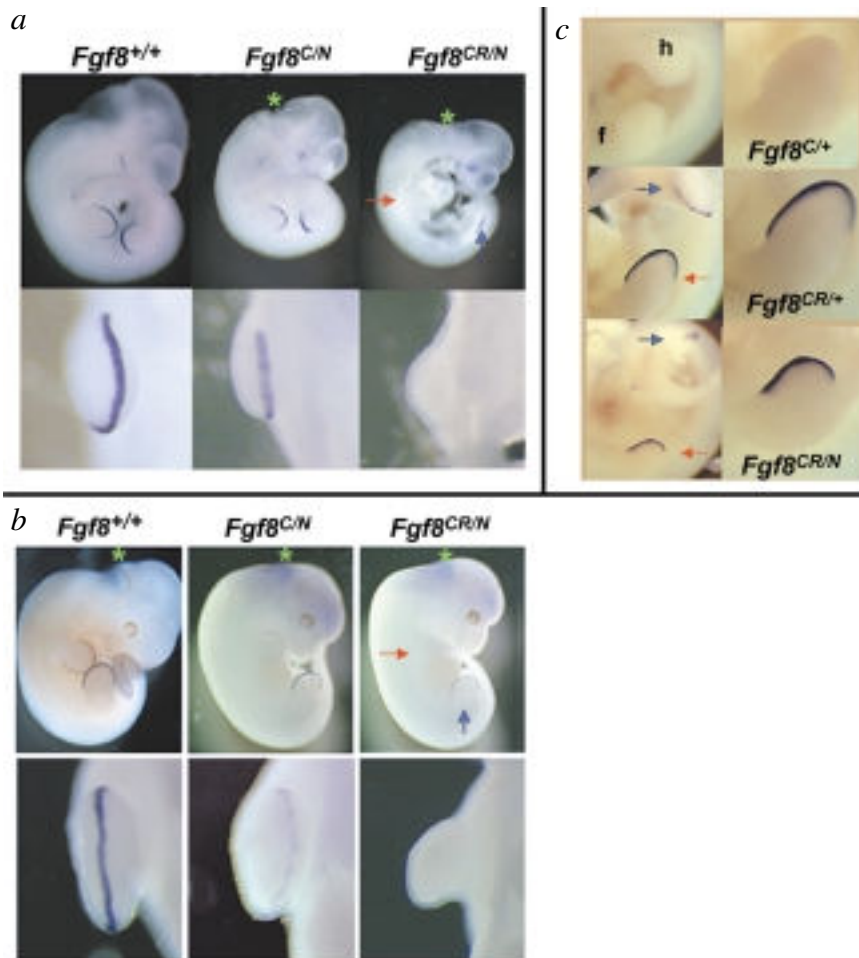

Fig. 2 *Fgf8* expression and alkaline phosphatase activity in embryos bearing mutant alleles of *Fgf8*. In this and all subsequent figures, *Fgf8* genotypes are listed at the top of the column. +, wild-type allele; N, null allele; C, conditional allele; CR, Cre-recombined conditional allele. All *in situ* hybridizations were performed with stage-matched littermates whenever possible and control and mutant embryos were hybridized in the same vials. **a**, *Fgf8* expression in E10.5 embryos. Top, whole embryos; bottom, higher magnification of forelimb buds. *Fgf8* transcripts were detected in hindlimb (blue arrow) but not forelimb AER (red arrow) of *Fgf8*^{CR/N} conditional mutants. *Fgf8*^{C/N} embryos (no RARCre transgene) have detectable *Fgf8* mRNA in both limb buds and normal bud morphology. Note small embryo size and abnormal head shape indicating abnormal hindbrain development (green asterisks) of *Fgf8*^{C/N} and *Fgf8*^{CR/N} animals derived from the hypomorphic conditional allele. **b**, *Fgf8* expression in E11.5 embryos. Note stepwise decrease in the amount of *Fgf8* transcripts with additional mutant alleles. The conditional mutant *Fgf8*^{CR/N} forelimb bud is small, abnormally shaped and lacks *Fgf8* transcripts (red arrow). **c**, Alkaline phosphatase activity in E10.5 embryos. There is no staining detectable in the absence of Cre recombinase (*Fgf8*^{C/+}). Expression of RARCre (*Fgf8*^{CR/+} or *Fgf8*^{CR/N}) resulting in recombination places AP coding sequences under control of the *Fgf8* promoter. AP enzymatic activity occurs only in those cells that express *Fgf8* and in which Cre-mediated recombination has occurred: the signal is strong and uniform in the forelimb AER (red arrow), whereas only a subset of hindlimb AER cells are stained (blue arrow).

Fgf8^C was conditionally inactivated with a Cre transgene under transcriptional control of the retinoic acid receptor β 2 promoter (official nomenclature: Tg(Rarb/Cre)1Mrc, henceforth referred to as RARCre). We, and others, have shown that this promoter is active in the developing forelimb region of transgenic mice before E9.0 (refs 13,17,18). Thus, RARCre is active early enough to result in complete inactivation of *Fgf8* in its expression domains in the forelimb¹⁻³. Because RARCre is expressed in every cell of the forelimb AER, but in only a few cells of the hindlimb AER (ref. 13), the hindlimbs of an embryo serve as internal controls for the phenotypic consequences of complete RARCre-mediated inactivation of *Fgf8* in the forelimbs. To demonstrate the forelimb specificity and timing of RARCre activity, we assayed for alkaline phosphatase activity in embryos containing an *Fgf8*^C allele and RARCre. We detected AP activity uniformly throughout the forelimb AER from the time of its formation (Fig. 2c), and in the ventral ectoderm of E9.0 forelimbs^{1,2} (data not shown).

To prove that RARCre-mediated recombination completely disrupted *Fgf8* function in the forelimb AER, we performed RNA *in situ* hybridization using an antisense *Fgf8* riboprobe. We detected *Fgf8* mRNA in both forelimb and hindlimb AERs of *Fgf8*^{C/N} embryos (no RARCre transgene), at expected levels relative to wild type. In contrast, *Fgf8* transcripts were detected in hindlimb, but not in forelimb, AER of the conditional mutants (*Fgf8*^{CR/N}; Fig. 2a,b). We did not find *Fgf8* transcripts in forelimbs of E9.0–12.0 mutant mice (data not shown).

Fgf8 inactivation in the forelimb AER resulted in aplasia of the radius and first digit with 100% penetrance (Fig. 3b). The humerus and second digit were also absent from most condi-

tional mutants (Fig. 3b). When present, the humerus was hypoplastic. The ulna was thickened and bowed; carpal bones were variably fused and/or absent. The effects of *Fgf8* inactivation were visible in mutants as early as E10.0; the limb buds were smaller and abnormally shaped, with loss of anterior mesenchyme and disorganization and deterioration of the AER (Figs 2–5).

The absence of anterior forelimb elements from conditional mutants, although *Fgf8* is deleted throughout the AER, demonstrates that *Fgf8* is absolutely required only in the anterior AER. *Fgf4* is expressed predominantly in the posterior AER and may compensate for the loss of posterior *Fgf8*. At E11.5, when AER *Fgf4* expression is normally waning, we detected increased *Fgf4* transcripts in conditional mutants (Fig. 4a,b, n=5). The intensity of the *Fgf4* signal is higher than that detected at any stage in controls (n=20). A slight increase in *Fgf4* expression was observed in *Fgf8*^{C/N} embryos ($\leq 50\%$ of the normal amount of *Fgf8* transcripts). Thus, the amount of *Fgf4* mRNA in the AER inversely correlates with a decrease (*Fgf8*^{C/N}) or loss (*Fgf8*^{CR/N}) of *Fgf8* in these cells. This observation suggests that levels of *Fgf4* and *Fgf8* are coregulated in the AER through an *Fgf8*-mediated negative regulatory mechanism (Fig. 4c), ensuring balanced production of these factors to mediate proper limb outgrowth. This hypothesis predicts that loss of both *Fgf4* and *Fgf8* function in the AER will result in truncation of the entire limb.

The loss of mesenchyme and AER in the anterior forelimb buds of conditional mutants can be partially explained by the increased apoptosis we observed in this region of E10.5 mutant embryos (Fig. 5a, n=5 mutants, n=25 controls). No differences in cell death were detected at E9.0 and E11.5 (data not shown).

The deficiency of anterior mesenchyme and skeletal phenotype of mutant forelimbs is similar to that described in chick embryos after anterior AER resection^{19,20}. In addition to increased apop-

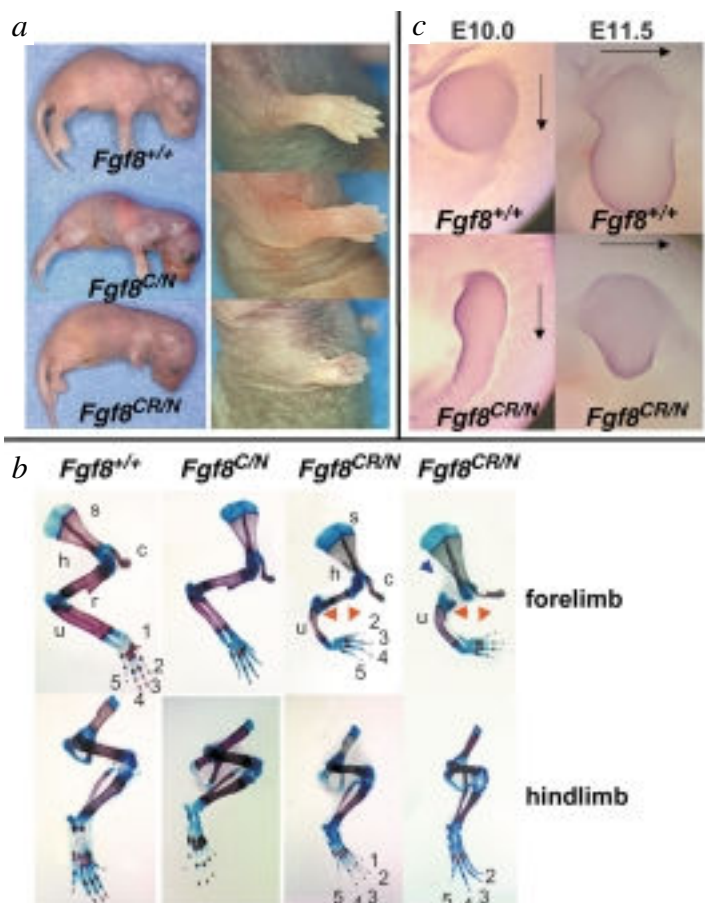

Fig. 3 Morphology of *Fgf8* conditional mutants. **a**, Gross morphology of newborn and postnatal day 1 animals and forelimbs. Conditional mutants (*Fgf8^{CR/N}*) display severe forelimb deformity resulting from ablation of *Fgf8* function during forelimb development. **b**, Skeleton preparations of limbs of newborns. The radius and first digit were absent from 100% (27/27) of conditional mutants (red arrowheads). Most also lacked the humerus (blue arrowhead; 19/27, 70%) and a second digit (14/27, 52%). At low penetrance (2/18, 10%), animals generated with the hypomorphic conditional allele lacked the first hindlimb digit, indicating that formation of this structure is sensitive to decreased levels of *Fgf8*; in animals bearing the nonhypomorphic conditional allele, this digit was always present. r, radius; h, humerus; s, scapula; c, clavide; u, ulna. **c**, Photomicrographs of E10.0 and E11.5 forelimb buds from conditional mutants and control littermates. Arrows point from anterior to posterior. Fixed, dehydrated embryos were briefly stained with eosin and haematoxylin to improve contrast. The deficiency in outgrowth and anterior mesenchyme is already apparent by E10.0, consistent with onset of Cre activity in the forelimb before E9.5.

onset of *Fgf4* expression is later than that of *Fgf8* may explain aplasia of the humerus in most conditional mutants. Incomplete penetrance of this phenotype may reflect inherent variability in the relative timing of *Fgf8* inactivation and onset of *Fgf4* expression. Even when the humerus is formed in these mutants, it is very hypoplastic, suggesting an ongoing requirement for *Fgf8* during humerus formation. Failure to form anterior components of the zeugopod and autopod may reflect the lack of spatial overlap between *Fgf8* and *Fgf4* expression in the anterior AER. As a result, *Fgf10* expression is decreased in the anterior PZ and there is increased apoptosis in this region of the limb bud.

The accompanying paper by Lewandoski *et al.*²⁷ also describes a *Cre/loxP*-mediated *Fgf8* conditional limb phenotype. The limb phenotypes obtained with the two different systems are instructive. Distinct patterns of Cre-transgene expression and subtle differences in the

tosis, abnormal proliferation and outgrowth may also contribute to the mutant phenotype. As mesenchymal *Fgf10* is required for limb outgrowth^{21,22} and *Fgf8* may be required to maintain *Fgf10* expression^{20,23}, we examined *Fgf10* expression in conditional mutants (Fig. 5*b,c*). Expression appeared normal in the posterior forelimb mesenchyme at E10.5, but decreased in the anterior half of the mutant forelimb. At E11.5, *Fgf10* expression appeared to be decreased in both the anterior and posterior extremes of the forelimb mesenchyme, suggesting that *Fgf8* signalling positively regulates *Fgf10*.

Given that *Fgf4* expression is increased in the AER of *Fgf8* conditional mutant forelimbs, and that *Fgf4* has been postulated to maintain *Shh* expression through a positive feedback loop^{24,25}, we were surprised to find that *Shh* expression was decreased at E11.5 in *Fgf8* conditional mutants (Fig. 6*a,b*, $n=6$). We, and others, have shown that *Shh* expression is normal in *Fgf4* conditional mutants^{13,14}. Our results suggest that *Fgf8*, rather than *Fgf4*, is required to maintain *Shh* expression.

Shh is thought to guide anterior-posterior patterning by inducing asymmetric expression of downstream genes (5' *Hoxd* genes, *Bmp2*; refs 10,24). *Bmp2* expression, however, appeared normal or slightly increased in conditional mutants at E10.5, and was increased at E11.5 in the forelimbs of these animals (Fig. 6*c,d*). These results are consistent with reports that asymmetry of gene expression in the limb mesoderm is not dependent on *Shh* expression²⁶ and suggests that *Bmp2* may be responsive to *Fgf* levels in the AER.

By conditionally inactivating *Fgf8* in the developing forelimb, we have demonstrated that *Fgf8* is required for formation of elements along the entire proximal-distal limb axis. That normal

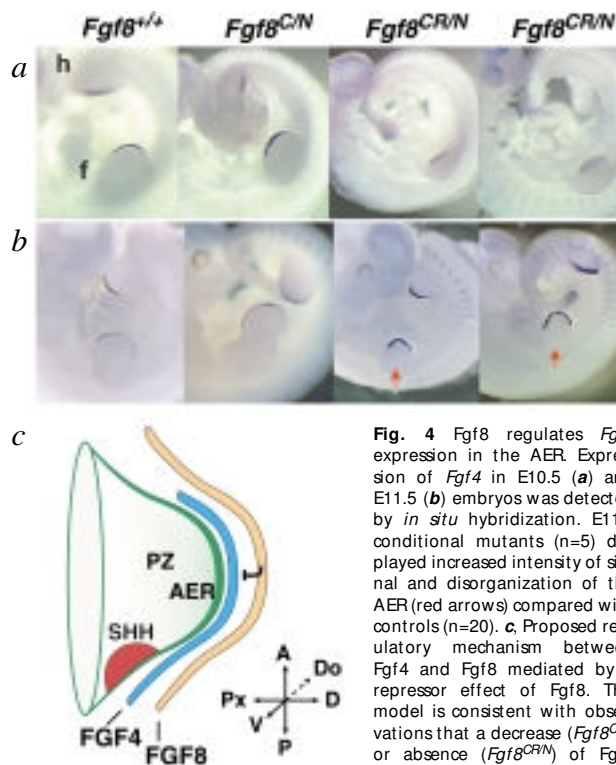

Fig. 4 *Fgf8* regulates *Fgf4* expression in the AER. Expression of *Fgf4* in E10.5 (**a**) and E11.5 (**b**) embryos was detected by *in situ* hybridization. E11.5 conditional mutants ($n=5$) displayed increased intensity of signal and disorganization of the AER (red arrows) compared with controls ($n=20$). **c**, Proposed regulatory mechanism between *Fgf4* and *Fgf8* mediated by a repressor effect of *Fgf8*. This model is consistent with observations that a decrease (*Fgf8^{C/N}*) or absence (*Fgf8^{CR/N}*) of *Fgf8* leads to increased expression of *Fgf4* in the AER.

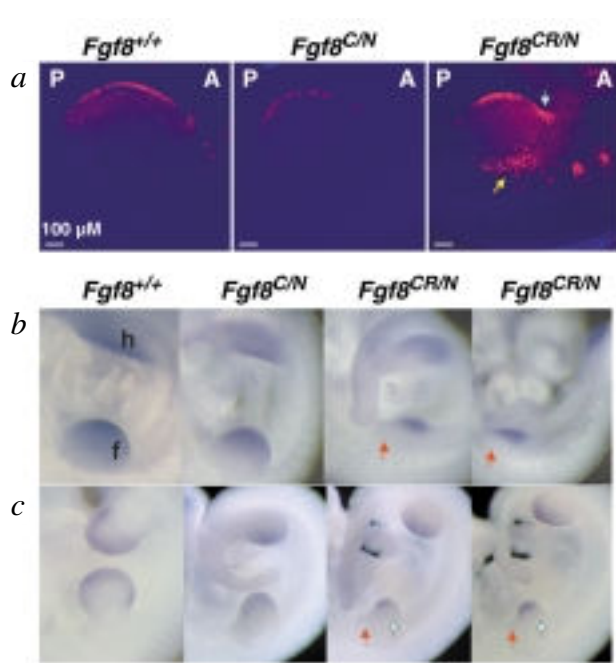

Fig. 5 Abnormal morphology and outgrowth of *Fgf8* conditional mutant forelimb buds results from increased apoptosis and decreased *Fgf10* expression. **a**, TUNEL assay on E10.5 embryos ($n=5$ mutants) reveals increased programmed cell death in the AER, anterior (blue arrow) and proximal (yellow arrow) limb bud mesenchyme, and somites of conditional mutants. *Fgf10* expression is decreased in the anterior mesenchyme of conditional mutant forelimbs (red arrows) at E10.5 (**b**) and E11.5 (**c**) ($n=4$ each). Expression in the posterior forelimb mesenchyme is also decreased at E11.5 (blue arrows); there is a central region with relatively intact expression. Hindlimb expression seemed to be normal.

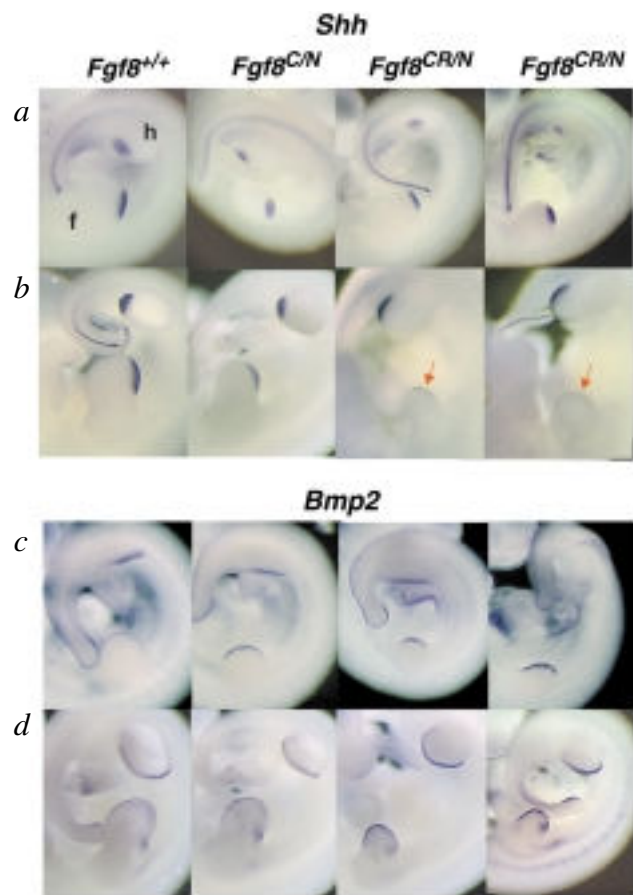

Fig. 6 *Shh* expression is not maintained in the ZPA of *Fgf8* conditional mutants, but asymmetry of *Bmp2* expression is preserved. **a**, At E10.5 *Shh* expression appears intact. **b**, By E11.5 a decreased amount of *Shh* mRNA is detected in the forelimbs of conditional mutant embryos (red arrows; $n=6$). **c**, *Bmp2* expression appears normal or slightly increased in conditional mutant forelimbs at E10.5. **d**, By E11.5 there is an increased *Bmp2* signal in the AER ($n=3$).

relative patterns of *Fgf4* and *Fgf8* expression in the fore- and hindlimbs likely account for the differences in mutant phenotypes reported. Both studies emphasize the importance of knowing the timing, location and efficiency of Cre-mediated inactivation to interpreting the resulting phenotype. Inclusion of a reporter gene that is concomitantly activated with the excision reaction is ideal¹³.

The RAR β 2 promoter we used to regulate Cre is expressed before AER formation in the forelimb buds, but minimally in the hindlimbs. We therefore anticipated and observed defects in forelimb development. The *Msx2* promoter used by Lewandoski *et al.* to drive Cre is not expressed sufficiently early to completely ablate *Fgf8* function during forelimb formation, resulting in a complex forelimb phenotype. The *Msx2* promoter is expressed early enough in the posterior embryo to yield clear hindlimb defects.

The respective forelimb and hindlimb defects observed in the two studies, although similar, are not identical. With the RARCre transgene the radius is not formed, whereas with *Msx2*Cre, the tibia (hindlimb radius equivalent) is formed. Careful comparison of *Fgf4* and *Fgf8* expression in normal embryos reveals greater overlap anteriorly in the hindlimb AER than in the forelimb AER. This would allow *Fgf4* to better compensate for loss of *Fgf8* in the anterior hindlimb AER and 'rescue' the tibia in the hindlimb. Rescue of the tibia is incomplete, however, because it is hypoplastic²⁷. The first digit is not formed in either the fore- or hindlimb in these mutants because *Fgf4* is not expressed in the extreme anterior AER. The difference in penetrance of aplasia of the humerus versus femur (70% versus 100%) in these two studies may be understood in terms of small differences in the relative timing of *Fgf4* and *Fgf8* expression in the fore- versus hindlimbs.

The formation of the distal bones in the absence of the stylopod in these conditional mutants illustrates that sequential development of proximal to distal limb elements is not obligatory. Integrated exposure to Fgfs emanating from the AER has been hypothesized to provide the 'distalizing' signal to PZ cells, which results in their progressive commitment to form more distal elements²⁸. Contrary to this prediction, both studies found that complete removal of *Fgf8* from the AER had more severe effects on formation of proximal than distal elements.

Limb deformities, including hemimelia with aplasia of the anterior zeugopod and autopod elements, are very common among human births (approximately 1% of humans are born with limb malformations²⁹). Our results suggest that abnormal *Fgf8* function during limb development may account for some of these birth defects.

Acknowledgements

We thank J. Tomlin for technical assistance; vivarium staff for their ongoing efforts; members of the Capecchi laboratory for input and critical reading of the manuscript; L. Oswald for assistance with preparing the manuscript; A. McMahon, B. Hogan, C. Deng and D. Ornitz for *in situ* probes; and J. Deschamps for the RAR β 2 promoter fragment.

Received 16 May; accepted 13 October 2000.

1. Heikinheimo, M., Lawshe, A., Shackelford, G.M., Wilson, D.B. & MacArthur, C.A. Fgf-8 expression in the post-gastrulation mouse suggests roles in the development of the face, limbs and central nervous system. *Mech. Dev.* **48**, 129–138 (1994).
2. Mahmood, R. *et al.* A role for Fgf-8 in the initiation and maintenance of vertebrate limb bud outgrowth. *Curr. Biol.* **5**, 797–806 (1995).
3. Crossley, H.P., Minowada, G., MacArthur, C.A. & Martin, G.R. Roles for Fgf-8 in the induction, initiation and maintenance of chick limb development. *Cell* **84**, 127–136 (1996).
4. Meyers, E.N., Lewandoski, M. & Martin, G.R. An Fgf8 allelic mutant allelic series generated by Cre- and Flp-mediated recombination. *Nature Genet.* **18**, 136–141 (1998).
5. Rubin, L. & Saunders, J.W. Ectodermal-mesodermal interactions in the growth of limb buds in the chick embryo: constancy and temporal limits of the ectodermal induction. *Dev. Biol.* **28**, 94–112 (1972).
6. Wolpert, L., Lewis, J. & Summerbell, D. Morphogenesis of the vertebrate limb. *Ciba Found. Symp.* **29**, 95–130 (1975).
7. Vogel, A., Rodriguez, C. & Izpisua-Belmonte, J.C. Involvement of FGF8 in initiation, outgrowth and patterning of the vertebrate limb. *Development* **122**, 1737–1750 (1996).
8. Ohuchi, H. *et al.* Involvement of androgen-induced growth factor (Fgf-8) gene in mouse embryogenesis and morphogenesis. *Biochem. Biophys. Res. Commun.* **204**, 882–888 (1994).
9. Cohn, M.J., Izpisua-Belmonte, J.C., Abud, H., Heath, J.K. & Tickle, C. Fibroblast growth factors induce additional limb development from the flank of chick embryos. *Cell* **80**, 739–746 (1995).
10. Riddle, R.D., Johnson, R.L., Laufer, E. & Tabin, C. Sonic Hedgehog mediates the polarizing activity of the ZPA. *Cell* **75**, 1401–1416 (1993).
11. Niswander, L., Tickle, C., Vogel, A., Booth, I. & Martin, G.R. FGF-4 replaces the apical ectodermal ridge and directs outgrowth and patterning of the limb. *Cell* **75**, 579–587 (1993).
12. Colvin, J.S., Feldman, B., Nadeau, J.H., Goldfarb, M. & Ornitz, D.M. Genomic organization and embryonic expression of the mouse fibroblast growth factor 9 gene. *Dev. Dyn.* **216**, 72–88 (1999).
13. Moon, A.M., Boulet, A.M. & Capecchi, M.R. Normal limb development in conditional mutants of Fgf4. *Development* **127**, 989–996 (2000).
14. Sun, X. & Martin, G. Conditional inactivation of Fgf4 reveals complexity of signaling during limb bud development. *Nature Genet.* **25**, 83–86 (2000).
15. Thomas, K.T. & Capecchi, M.R. Site-directed mutagenesis by gene targeting in mouse embryo-derived stem cells. *Cell* **51**, 503–512 (1987).
16. Dymecki, S.M. Fp recombinase promotes site-specific recombination in embryonic stem cells and transgenic mice. *Proc. Natl Acad. Sci. USA* **93**, 6191–6196 (1996).
17. Reynolds, K., Mezey, E. & Zimmer, A. Activity of the B-retinoic acid receptor promoter in transgenic mice. *Mech. Dev.* **36**, 15–29 (1991).
18. Mendelsohn, C., Ruberte, E., LeMeur, M., Morriss-Kay, G. & Chambon, P. Developmental analysis of the retinoic acid-inducible RAR-B2 promoter in transgenic animals. *Development* **113**, 723–734 (1991).
19. Rowe, D.A. & Fallon, J.F. The effect of removing posterior apical ectodermal ridge of the chick wing and leg on pattern formation. *J. Embryol. Exp. Morph.* **65**, 309–325 (1981).
20. Ohuchi, H. *et al.* The mesenchymal factor, FGF10, initiates and maintains the outgrowth of the chick limb bud through interaction with FGF8, an apical ectodermal factor. *Development* **124**, 2235–2244 (1997).
21. Min, H. *et al.* Fgf-10 is required for both limb and lung development and exhibits striking functional similarity to Drosophila branchless. *Genes Dev.* **12**, 3156–3161 (1998).
22. Sekine, K. *et al.* Fgf10 is essential for limb and lung formation. *Nature Genet.* **21**, 138–141 (1999).
23. Xu, X. *et al.* Fibroblast growth factor receptor 2-mediated reciprocal regulation loop between FGF8 and FGF10 is essential for limb induction. *Development* **125**, 753–765 (1998).
24. Laufer, E., Nelson, C.E., Johnson, R.L., Morgan, B.A. & Tabin, C. Sonic hedgehog and Fgf-4 act through a signaling cascade and feedback loop to integrate growth and patterning of the developing limb bud. *Cell* **79**, 993–1003 (1994).
25. Niswander, L., Jeffery, S., Martin, G.R. & Tickle, C. A positive feedback loop coordinates growth and patterning in the vertebrate limb. *Nature* **371**, 609–614 (1994).
26. Ros, M.A. *et al.* The limb field mesoderm determines initial limb bud anteroposterior asymmetry and budding independent of sonic hedgehog or apical ectodermal gene expressions. *Development* **122**, 2319–2330 (1996).
27. Lewandoski, M., Sun, X. & Martin, G.R. Fgf8 signalling from the AER is essential for normal limb development. *Nature Genet.* **26**, 460–463 (2000).
28. Tabin, C. A developmental model for thalidomide defects. *Nature* **396**, 322–323 (1998).
29. Rogala, E.J., Wynne-Davis, R., Littlejohn, A. & Gormley, J. Congenital limb anomalies: frequency and aetiological factors. *J. Med. Genet.* **11**, 221–233 (1974).
30. Tanaka, A. *et al.* Cloning and characterization of an androgen-induced growth factor essential for the androgen-dependent growth of mouse mammary carcinoma cells. *Proc. Natl Acad. Sci. USA* **89**, 8928–8932 (1992).