

Capacitance and Inductance Sensor Circuits for Detecting the Lengths of Open- and Short-Circuited Wires

You Chung Chung, *Senior Member, IEEE*, Nirmal N. Amarnath, and Cynthia M. Furse, *Fellow, IEEE*

Abstract—The length of an open- or short-circuited wire is linearly proportional to the capacitance or inductance of the wire, respectively. Several types of simple and inexpensive circuits are introduced to measure these values. Open-circuited (capacitance) measurements are very effective. Short-circuited (inductance) measurements are more difficult, and not all of the circuits worked well. A 555 timer circuit was found to have the best overall performance to locate the ends of both open- and short-circuited wires. The capacitance and inductance values of various types of aircraft wires were measured and verified with analytical equations.

Index Terms—Aging aircraft wire, capacitance sensor, fault detection, inductance sensor.

I. INTRODUCTION

AGING WIRING has been identified as an area of critical national concern [1]. Miles of aging wires are buried inside virtually all of the major structures and systems with which we are familiar. Wiring is pervasive in private, commercial, and military aircraft; trains and other vehicles; industrial machinery; homes and buildings; communication networks; overland power distribution lines; nuclear reactors; control systems; etc. As these wires age, they may begin to crack and fray or break, corrode, or be damaged by careless maintenance.

Detecting and locating these faults are extremely important, and there are several existing and emerging methods for doing this. Reflectometry methods send a high-frequency signal (e.g., step, pulse, sine wave, and pseudonoise code) down the wire, where it reflects off impedance discontinuities, such as open or short circuits. The time delay (or equivalent phase delay) between the incident and reflected signals tells the distance to the fault. These methods have been shown to be highly effective,

Manuscript received July 22, 2007; revised July 29, 2008. First published March 10, 2009; current version published July 17, 2009. This work was supported by the Air Force Research Laboratory and Daegu University Research Grant 2004.

Y. C. Chung is with the Information and Communication Engineering, Daegu University, Gyeongsan 712-714, Korea (e-mail: youchung@daegu.ac.kr).

N. N. Amarnath was with the Department of Electrical Computer Engineering, University of Utah, Salt Lake City, UT 84112 USA.

C. M. Furse is with the Department Electrical and Computer Engineering and the Center of Excellence for Smart Sensors, University of Utah, Salt Lake City, UT 84112 USA, and also with LiveWire Test Labs, Inc., Salt Lake City, UT 84117 USA (e-mail: cfurse@ece.utah.edu).

Color versions of one or more of the figures in this paper are available online at <http://ieeexplore.ieee.org>.

Digital Object Identifier 10.1109/TIM.2009.2014617

cost effective (on the order of \$20/sensor), and miniaturizable for some applications; however, other applications require devices that are even less expensive. Capacitance sensors may be the most effective solution for some types of very price-sensitive wire fault-location applications [2]–[4].

The capacitance of an open-circuited wire and the inductance of a short-circuited wire are linearly proportional to their lengths, and capacitance measurements have been used to locate open circuits on wires [5]. Capacitance sensors are very simple and inexpensive and require testing from only one end of the cable. However, short circuits are, by far, the largest problem of aging wiring, and the capacitance sensor in [5] does not work for short-circuited wires since this is inductive rather than capacitive.

Many different capacitance-sensing methods have been used for motion, position, or pressure sensors [6]–[9]. Most methods are not accurate enough to handle the very small variations in capacitance that are required for locating wire faults to within a few inches. An interface circuit for measuring very small capacitance changes with a double-difference principle using active rectifiers, a low-pass filter, and an analog-to-digital converter is given in [10]. A circuit measuring the differential capacitance using a current detector and an amplitude modulation–demodulation circuit is given in [11].

This paper compares several different methods of measuring the length of open-circuited wires using capacitance. These simple circuits are also adapted to measure inductance so that the lengths of short-circuited wires can also be measured. The performance of several different types of circuits are compared to measure the lengths of both open- and short-circuited aircraft wires. The capacitance and inductance of 13 different aircraft wire types are summarized in Section II. Several different capacitance and inductance measurement circuits (e.g., a three-gate oscillator, two-inverter oscillator, Schmitt trigger oscillator, differential amplifier, and 555 timer) are compared in Section III to measure the length of open- and short-circuited wires.

II. CAPACITANCE AND INDUCTANCE OF WIRE

When designing sensors for measuring the length of wire based on its capacitance or inductance, it is important to understand the range and variation of these values for realistic wire types. This section analytically and experimentally evaluates these values for typical aircraft wire types. An exhaustive

summary of aircraft wire types is impractical; therefore, this section represents a range of typical values.

The capacitance value C of any two conductors is based on the distance D between them, the cross-sectional area of the conductor S , and the permittivity ε (in farads per meter) of the dielectric material separating them, i.e., $\varepsilon(\varepsilon = \varepsilon_r \varepsilon_0, \varepsilon_0 = 8.854 \times 10^{-12} \text{ F/m})$ of the dielectric separating the conductors. ε_r is the relative permittivity of the insulation

$$C = \varepsilon \frac{S}{d}. \quad (1)$$

The capacitance and inductance per unit length of parallel insulated round wires have been modeled and calculated [12]–[15] using

$$C = \frac{\pi \varepsilon}{\cosh^{-1}\left(\frac{D}{d}\right)} \text{ (F/m)} \quad (2)$$

$$L = \frac{\mu}{\pi} \cosh^{-1}(D/d) \text{ for high frequency (H/m)} \quad (3)$$

$$L = \frac{\mu}{\pi} \left[1/4 + \cosh^{-1}(D/d) \right] \text{ for low frequency (H/m)} \quad (4)$$

where d is the diameter of the conductors, D is the distance between the centers of the conductors, and ε is the permittivity of the insulation. μ is the magnetic permeability of the dielectric ($\mu = \mu_r \mu_0$, with $\mu_0 = 4\pi \times 10^{-7} \text{ H/m}$). μ_r is the relative permeability. The μ_r and ε_r of polyethylene insulation are about $0.994 \sim 1.0017$ and $2.5 \sim 2.7$, respectively.

Twisted-pair wires have about 20% greater capacitance than simple parallel wires due to the extra length from the twists [13]. This capacitance is given from endpoints, i.e., from a to b

$$C_{\text{total}} = \frac{\pi \varepsilon_0}{\cosh^{-1}\left(\frac{D}{d}\right)} + \int_a^b \frac{\varepsilon_0 dx}{D - \sqrt{d^2 - x^2}} + \int_a^b \frac{\varepsilon_0 dx}{D + (1.0/\varepsilon_r - 1.0)\sqrt{D^2 - x^2} - \frac{\sqrt{d^2 - x^2}}{\varepsilon_r}} \text{ (F/m)}. \quad (5)$$

The capacitance and inductance values of coaxial cables are

$$C = \frac{2\pi \varepsilon}{\ln(b/a)} \text{ (F/m)} \quad (6)$$

$$L = \frac{\mu}{2\pi} \left[\ln \frac{b}{a} + \frac{1}{4} + \frac{1}{4(c^2 - b^2)} \left(b^2 - 3c^2 + \frac{4c^4}{c^2 - b^2} \ln \frac{c}{b} \right) \right] \text{ (H/m)} \quad (7)$$

where a is the radius of the inner conductor, and b and c are the inner and outer radii of the shield, respectively [14], [15]. ε and μ are the permittivity and permeability of the insulation between the inner conductor and the shield.

Fig. 1 shows the capacitance values of 13 different open-circuited aircraft wires as a function of length measured using

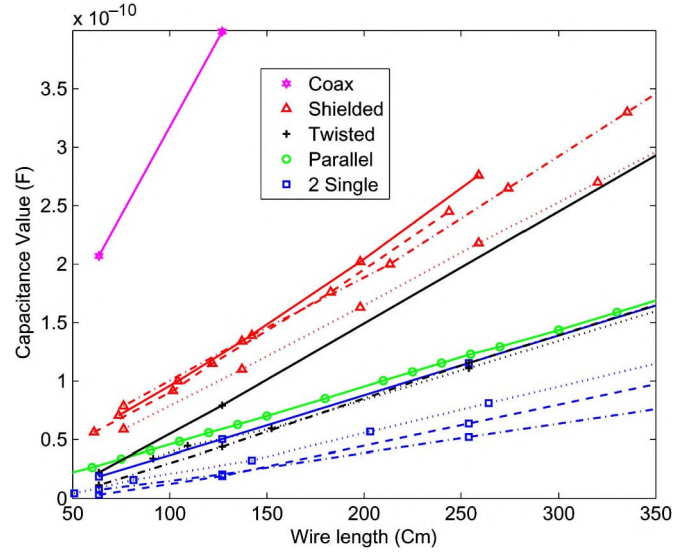

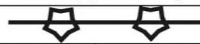





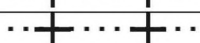





Fig. 1. Measured capacitance versus wire length of 13 different open-circuited aircraft wires given in Table I.

an HP4262A LCR meter, which are summarized in Table I. In Fig. 1, the only two data points of the coaxial cable are shown since the capacitance of the coaxial cable is very large and has a perfectly linear relationship with the length. Fig. 2 shows the inductance values of the same wires when they are short circuited. The coaxial cable is seen to have the largest capacitance per unit length, followed by the shielded twisted-pair cable, whose capacitance is slightly higher than that of the single parallel wires, as expected. For all types, the thicker wire (lower gauge) has larger capacitance per unit length. The single parallel wires in a bundle have the lowest capacitance value since the distance between the wires is large. Within a bundle of wires (often 20–150 wires), the distance between any two conductors is not constant, so the capacitance and inductance slightly vary throughout the bundle and for a single wire as it (often) meanders through the bundle. Variations of about 4 pF out of 350 pF and 0.01 μH out of 9.20 μH for 392 in (9.95 m)-long M22759/16-22-90 in a bundle of 20 wires were measured.

In Figs. 1 and 2, it can be seen that wires with higher capacitance values also have lower inductance values. Three different types of shorts were measured: 1) a simple short at the end; 2) a short at the middle of the wire, with the remaining length of the wire left open; and 3) a short at both the middle and the end of the remaining length of the wire. The inductance value with the short at the middle of the wire is the same as that with the simple short at the end of a wire that is half as long. This is good (and expected), because it means that additional lengths of wire do not corrupt the measurement of the distance to the short.

Clearly, the capacitance and inductance can be used to measure the length of wires and the distance to faults. There are numerous circuits for capacitance measurement [16], and they are not all equally effective. After adapting the circuits or measuring both the capacitance and inductance, we discuss the capabilities, advantages, and disadvantages of several types of these sensor circuits in the next section.

TABLE I
MEASUREMENT RESULTS OF THE CAPACITANCE AND INDUCTANCE OF WIRES

Wire Type	Part Number	Line Type for Fig. 1	pF/m	μH/m
Coax	C4931-22L		339	0.161
Twisted shielded quadruple	M27500-22SC4S23		106.5	0.517
Twisted shielded triple	M27500-24SC3S23		100.5	0.55
Twisted pair shielded	M27500-2408T23		102.4	0.544
Twisted pair shielded	M27500-24SE2S23		84.7	0.614
Thick twisted triple	M81381-11-12		90.29	0.467
twisted pair	C4932-26L2		49.61	0.659
twisted pair	M27500-24SC2U00		47.28	0.587
parallel pair speaker wire	20 gage		49.27	0.785
thick single pair in a bundle	M81381-11-12 (C4932-12N3)		49.34	0.651
single pair in a bundle	M81381/7-20-2 (C4928-20)		31.76	0.976
single pair in a bundle	M22759/16-22-90		35.15	0.924
single pair in a big bundle	M22759-43-22-9		23.36	1.08

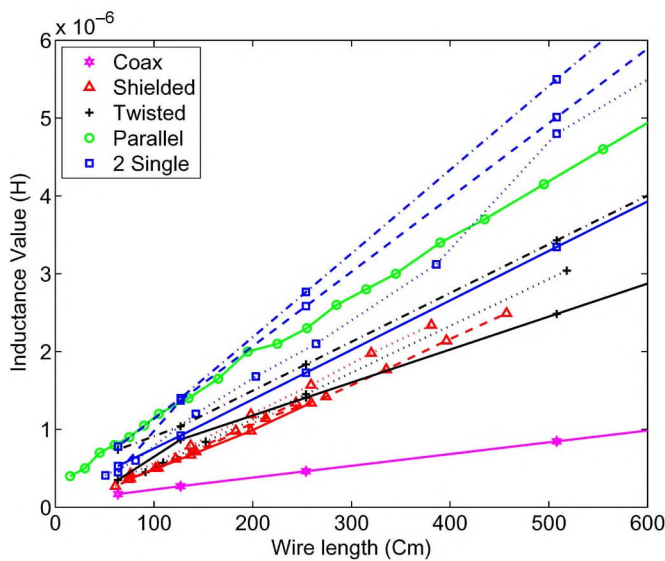

Fig. 2. Measured inductance versus wire length of 13 different open-circuited aircraft wires given in Table I.

III. CAPACITANCE AND INDUCTANCE SENSORS

Sensors that measure the capacitance and inductance of wires can broadly be divided into two categories. One type of sensor uses the wire as an inductive or capacitive element in a resonator circuit. The square-wave generator, three-gate oscillator, two-inverter oscillator, Schmitt trigger oscillator, differential amplifier, and 555 timer circuits fall into this category. Another set of sensors uses the capacitance or inductance of the wire as impedance and produces a measurable voltage drop. The voltage divider is an example of this class of sensor. Some circuits are more susceptible to stray capacitances or inductances; are more or less accurate; have ranges of measurement that are more or less effective; and, in general, work better in measuring the wire length or distance to fault than other methods. The next section gives detailed information on the

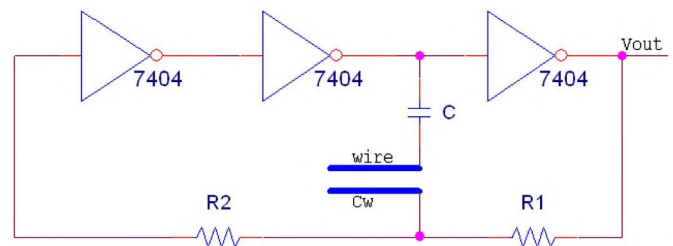

Fig. 3. Three-gate oscillator with capacitor C for short-circuited-wire measurements and without capacitor C for open-circuited-wire measurements.

different sensor circuits tested using a 20-gauge speaker wire, as given in Table I.

The voltage divider circuit can be used only for capacitance measurement and cannot locate short circuits [17]. A square-wave generator can measure the capacitance of the wire using the frequency of the square wave [18], [19]. The square-wave generator and voltage divider have been tested, but the results are not shown here since they are very well known. These circuits have two major limitations: First, it can only measure open circuits. Second, the change in frequency is very small for wires up to 7 m long, thus requiring a very sensitive frequency measurement circuit to complete this sensor [20].

A. Three-Gate Oscillator

The three-gate oscillator circuit shown in Fig. 3 uses the capacitance of the wire C_w to delay the signal passing through an odd number of logic gates and create an oscillation. It does not require a signal source [21]. The frequency output of the oscillator depends only on the propagation delay in the ring introduced by the inverters and capacitance. The propagation delay of such inverters is on the order of a few nanoseconds. Thus, the output frequency will be very high. The frequency can be controlled by the capacitance of the open-end wire and the inductance of the shorted wire, as shown in Fig. 3. This circuit can be used to measure both open- and short-circuited wires,

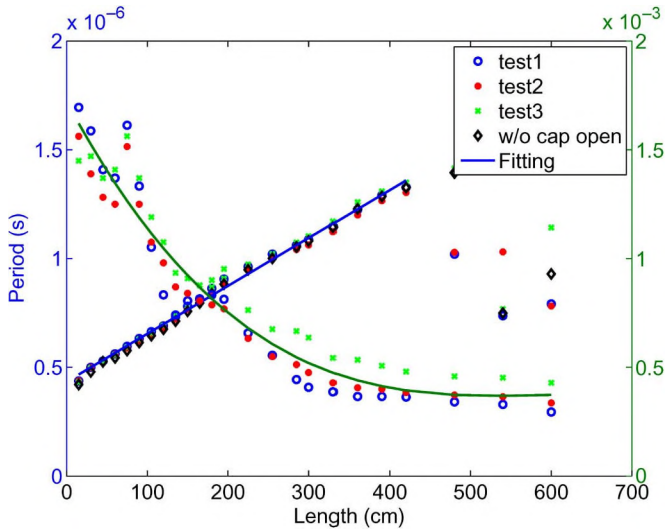

Fig. 4. Length versus period for open- and short-circuited wires using the three-gate oscillator.

by adding reference capacitor $C = 0.1 \mu\text{F}$ for short-circuited wires. The frequency output of this oscillator, as shown in Fig. 4, can be calculated using the expressions given here for open- or short-circuited wires.

- Open circuit:

Without Capacitor C :

$$f(\text{Hz}) = 1/[2 C_w(0.405R_{eq} + 0.693R_1)] \quad (8a)$$

With Capacitor C :

$$f(\text{Hz}) = (C_w + C)/[2 C C_w(0.405R_{eq} + 0.693R_1)] \quad (8b)$$

where $R_{eq} = R_1R_2/(R_1 + R_2)$, C is the reference capacitance, and C_w is the capacitance of the open-circuited wire.

- Short circuit: The wire is inductive, instead of capacitive. Reference capacitor C is required. The output frequency is given by

$$f(\text{Hz}) = 1/[\{2 C (0.405R_{eq} + 0.693R_1)\} + (39.48L_wC)] \quad (9)$$

where L_w is the inductance value of the short-circuited wire, and $R_{eq} = R_1R_2/(R_1 + R_2)$.

Capacitor C , which is required for short-circuit testing, limits the range of the circuit for open-circuit testing. Using $C = 0.1 \mu\text{F}$, $R_1 = 10 \text{ k}\Omega$, and $R_2 = 1 \text{ k}\Omega$, the frequency remained linear through an open-circuited wire that is about 450 cm long, as shown in Fig. 4. The value of the reference capacitor for the short circuit does not change the maximum testable length; however, smaller reference capacitors lead to errors for wires that are shorter than 100 cm. The frequency output of the sensor is very sensitive to the gate voltage. The short-circuited-wire measurements are unstable, and the frequency output oscillates by as much as 40 Hz over 1 min. Therefore, the maximum error of this circuit is relatively high.

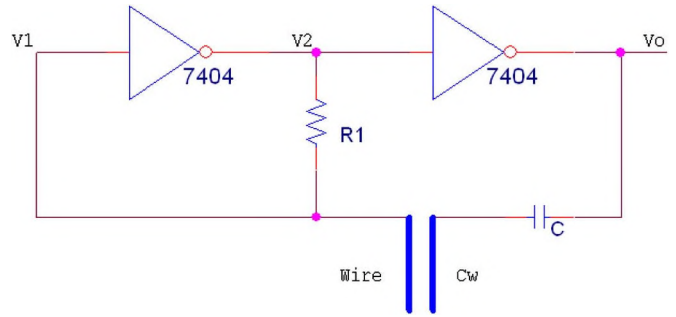

Fig. 5. Two-inverter oscillator with capacitor C for short-circuited-wire measurements and without capacitor C for open-circuited-wire measurements.

B. Two-Inverter Oscillator

A two-inverter oscillator shown in Fig. 5 is a stable multivibrator [21]. It consists of two inverters and an RC network. The output of each inverter is either logic 0 or logic 1, each corresponding to a fixed voltage. The input v_1 can slowly vary between certain limits, because it is the voltage of the insulated gate. No current flows into the input. The only possible current path is between nodes v_2 and v_0 . When v_1 is logic 1, v_2 and v_0 will be logic 0 and logic 1, respectively. Then, v_1 is greater than the inverter switching voltage. The voltage across R_1 produces a current that charges the capacitance of the wire, causing the voltage across capacitor C , i.e., v_c , to rise and v_1 to drop. When v_1 is below the inverter switching voltage, the inverters switch states. The respective logic levels of v_2 and v_0 are now 1 and 0. The current reverses, and v_c drops until v_1 rises above the inverter switching voltage. Then, the inverters switch states again, making the circuit function as an oscillator.

The frequency output of this oscillator can be estimated using the expressions given here.

- Open circuit:

Without Capacitor C $f(\text{Hz}) = 1/(5 C_w R_1)$ (10a)

With Capacitor C $f(\text{Hz}) = (C_w + C)/(5 C C_w R_1)$. (10b)

- Short circuit:

With Capacitor C $f(\text{Hz}) = (1 + L_w C_w)/(5 R_1 C_w)$ (11)

where C is the reference capacitance (which is necessary to enable locating short circuits), C_w is the capacitance due to the open-circuited wire, and L_w is the inductance due to the length of a shorted wire.

The values chosen for the oscillator are $R_1 = 1 \text{ k}\Omega$ and V_{cc} above 3.2 V for the 74LS04 IC used. Capacitor $C = 50 \text{ pF}$ limits the range of the sensor to 6 m for short circuits. The relationships between length and output period for open- and short-circuited wires are shown in Fig. 6. The sensor output is very sensitive to the supply voltage, and therefore, a well-regulated voltage is required. In addition, the output frequency ranges of both the open and short circuits overlap so that another test or *a priori* knowledge about whether the load is open or short is required.

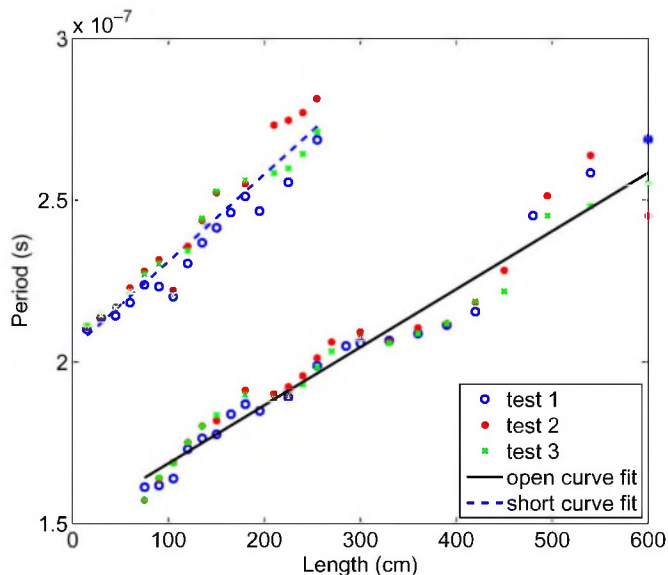

Fig. 6. Length versus output period for open- and short-circuited wires using the two-inverter oscillator.

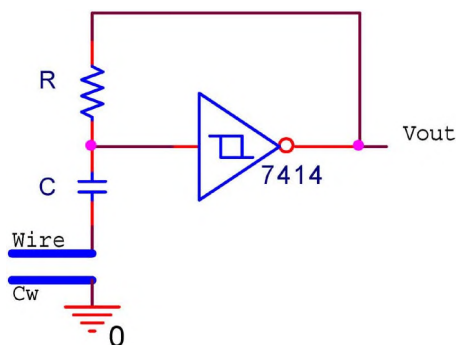

Fig. 7. Schmitt trigger oscillator with capacitor C for short-circuited-wire measurements and without capacitor C for open-circuited-wire measurements.

C. Schmitt Trigger Oscillator

A Schmitt trigger oscillator used as an astable multivibrator [22], as shown in Fig. 7 can be used to measure the capacitance and inductance of the wires and their lengths. The Schmitt trigger circuit is used in combination with a resonant circuit to create an oscillator, using the wire as one of the oscillating elements. The output of the Schmitt trigger is either $+V_{SAT}$ or $-V_{SAT}$. When the output is at $+V_{SAT}$, wire capacitance C_w will start charging. The voltage on the capacitor will increase until it exceeds the reference voltage, at which point, the output of the Schmitt trigger will change to $-V_{SAT}$. Then, C_w starts to discharge until it falls below the reference voltage. The output of the Schmitt trigger then switches back to $+V_{SAT}$, enabling the circuit to function as an oscillator. The frequency output of this oscillator can be estimated using the expressions given here [22].

- Open circuit:

$$\text{Without Capacitor } f(\text{Hz}) = 0.8/(C_w R) \quad (12a)$$

$$\text{With Capacitor } f(\text{Hz}) = 0.8(C_w + C)/(C C_w R). \quad (12b)$$

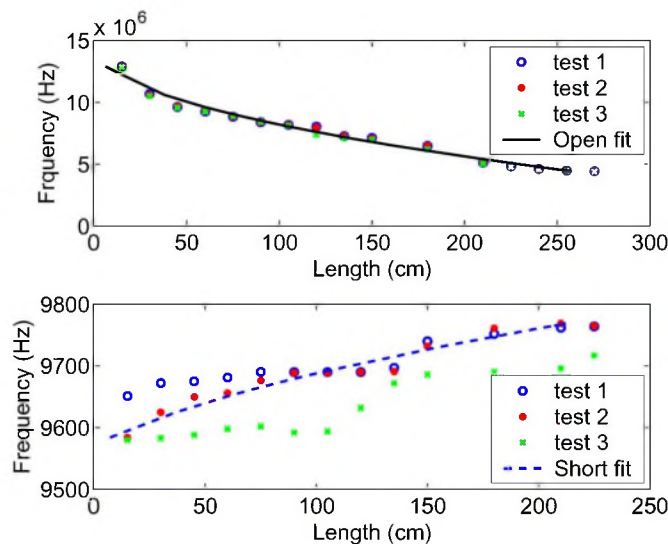

Fig. 8. Length versus output frequency for open- and short-circuited wires using the Schmitt trigger circuit.

- Short circuit:

$$\text{With Capacitor } f(\text{Hz}) = 0.8(1 + L_w C_w)/(R C_w) \quad (13)$$

where C is the reference capacitance, C_w is the capacitance due to the open-circuited wire, and L_w is the inductance due to the shorted wire. The output frequencies for open- and short-circuited wires are approximately linearly dependent on wire length, as shown in Fig. 8, using $R = 1 \text{ k}\Omega$. The major disadvantage of this circuit is that the short-circuited measurements are very unstable with time, varying by as much as 20 Hz over 1 min.

D. Differential Amplifier

The voltage follower and differential amplifier shown in Fig. 9 can be used to measure very sensitive changes in capacitance and inductance and, hence, the length of the open- and short-circuited wires. The impedance of the wire connected to the amplifier in Fig. 9 at the “+” input pin can be set as complex variable “ Z .” The amplifier output is fed to the differential amplifier, and the voltage follower output (which is the same as the input voltage) is fed to the noninverting terminal of the differential amplifier. When R_1, R_2, R_4 , and R_5 are of the same value, the output of differential amplifier can be simplified as given here.

- Open circuit:

$$\begin{aligned} \text{Without Capacitor } V_o &= [(1 + (R_f/Z)) V_{in}] - V_{in} \\ &= (R_f/Z) V_{in} \end{aligned} \quad (14a)$$

$$\text{With Capacitor } V_o = (V_{in} R_f \omega C C_w)/(C_w + C). \quad (14b)$$

- Short circuit:

$$\text{With Capacitor } V_o = (V_{in} R_f \omega C^2)/(L_w \omega^2 C - 1) \quad (15)$$

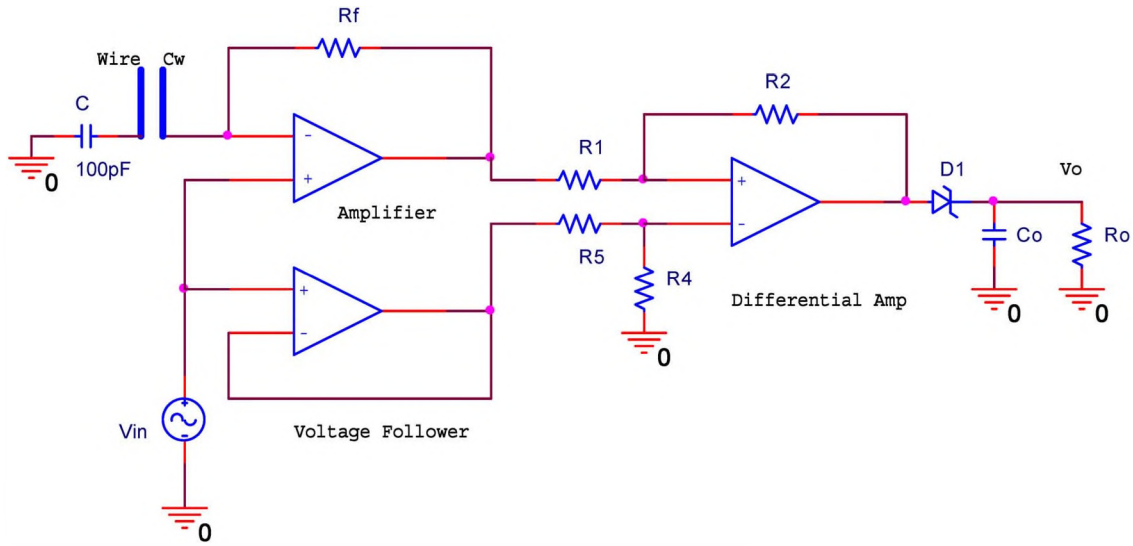

Fig. 9. Differential amplifier and voltage follower with capacitor C for short-circuited-wire measurements and without capacitor C for open-circuited-wire measurements.

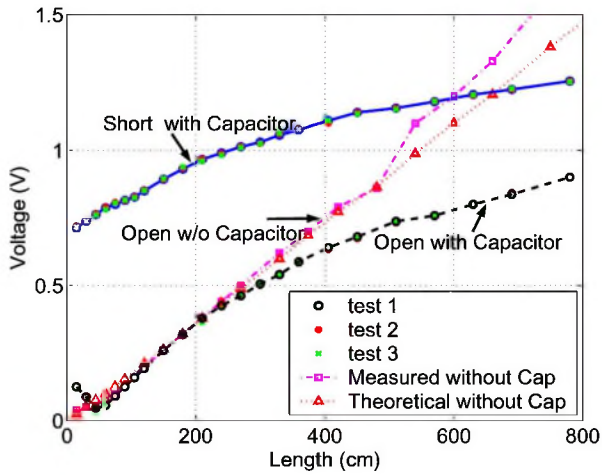

Fig. 10. Length versus voltage for open- and short-circuited wires using the differential amplifier.

where R_f is the feedback resistance, C is the reference capacitance, C_{ow} is the capacitance due to the open-circuited wire, and L_{sw} is the inductance due to the short-circuited wire.

The voltage output is linear with respect to the length of the wire for open-circuited wires when reference capacitor $C = 100$ pF is not used, as shown in Fig. 10. The theoretical output voltage and capacitance values (14a) are well matched for wires up to 450 cm long. The reference capacitor makes the response nonlinear for wires longer than 4.5 m, as shown in Fig. 10. For the circuit with the reference capacitor, there is an overlap of the output voltage of open and short circuits for wires longer than 450 cm, which means that an additional test to determine if the wire is open or short circuited would be required for longer wires. There is also an ambiguous region around 50 cm for the open-circuited wire with the reference capacitor.

In Fig. 10, it can be seen that the output is not very stable for short-circuited wires. The sensor is very stable for open-circuited measurements for wires that are more than 4.5 m long.

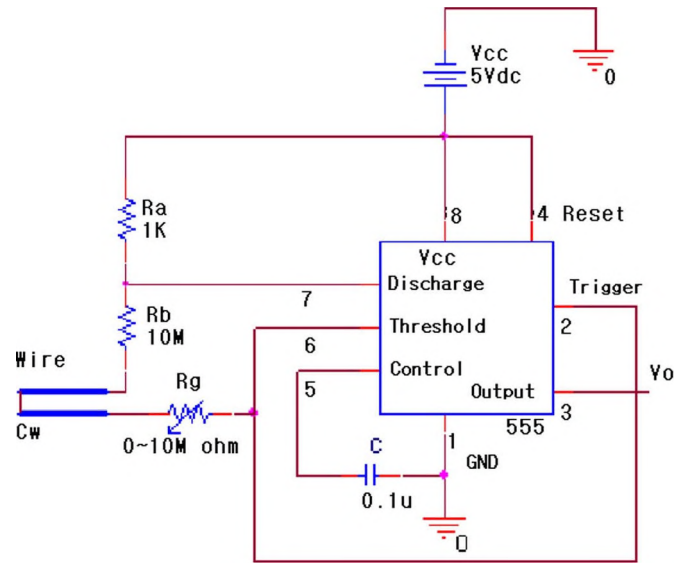

Fig. 11. Timer sensor for short-circuit fault detection. Connecting a short-circuit wire between R_b and R_g .

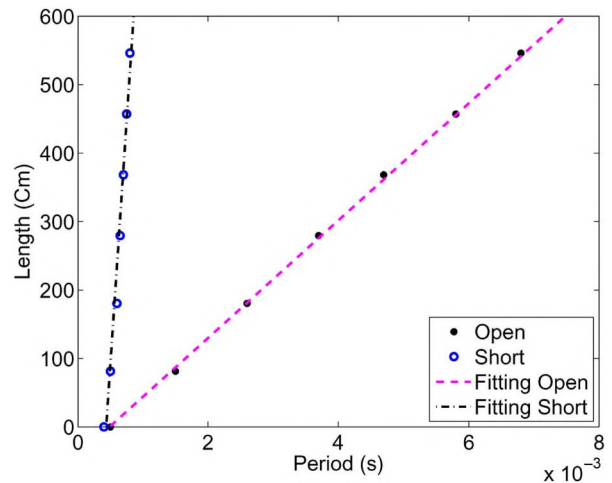

Fig. 12. Timer output period versus length of twisted-pair shielded wire M27500-24SE2S23.

TABLE II
COMPARISON OF METHODS FOR DETECTING BOTH OPEN AND SHORT CIRCUITS

Sensors	Open (cm)			Short (cm)		
	Max. Length	Max. Error	Min Error	Max Length	Max. Error	Min Error
Voltage divider	900	17.98	0.2059	NA	NA	NA
Square wave generator	900	22.75	0.3077	NA	NA	NA
Three gate oscillator	420	21.44	0.0292	600 (C=0.1 μ F)	405.63	0.2122
Two inverter oscillator	600	63.19	1.9117	255 (C=50 pF)	46.62	0.8414
Schmitt trigger oscillator	270	17.99	0.2466	225 (C=0.1 μ F)	100.36	2.5750
Differential Amplifier	225	7.93	0.0984	225 (C=100 pF)	28.43	0.0134
555 Timer	>6000	5.3	0.01	Less than infinity	20	0.5

The maximum length of a short-circuited wire that can be measured is 425 cm. The output voltage is very small and cannot accurately be measured for a wire that is longer than 425 cm.

E. 555 Timer Circuit

A 555 timer set up as an astable multivibrator is another method that locates faults on the open-circuited wire [5]. The frequency of the voltage output is

$$f(\text{Hz}) = 1.443 / [(R_a + 2R_b)C]. \quad (16)$$

The circuit must be adapted to test short-circuited wires, as shown in Fig. 11. The values used are $R_a = 1 \text{ k}\Omega$ and $R_b = 10 \text{ M}\Omega$ to obtain a 50% oscillation duty cycle. This circuit can distinguish between open and short circuits, because, when the circuit is used in the wrong configuration (open circuit in [5] when testing short), it produces a dc (null) output. The period of the output is plotted in Fig. 12, and both open- and short-circuited configurations are very linear. The maximum length that we have tested is 60 m long. This circuit can locate faults on wires that are up to about 1000 m long by changing the values of R_g in Fig. 11.

IV. COMPARISON OF METHODS AND CONCLUSION

The different methods discussed in this paper are summarized in Table II. The two-inverter oscillator and Schmitt trigger oscillator circuits could not accurately locate short circuits. All the circuits were more accurate for open circuits (capacitance) than short circuits (inductance), which is understandable since the inductance of the wire is strongly impacted by its metallic surroundings. The 555 timer and differential amplifier can locate both open- and short-circuited wires with the least error. The maximum errors for the timer for open and short circuits were 5.3 and 20 cm, respectively, and those for the differential amplifier were 7.93 and 28.43 cm, respectively.

Calibration of these systems can be done by measuring wires of the type that will later be tested and storing the coefficients of a linear fit to that data. If no calibration is done and the average values are used, errors on the order of 1%–5% for the open circuit and 1%–20% for the short circuit would be seen; therefore, it is strongly recommended that the type of wire and its gauge be known and used for calibration.

Some of the important limitations of all of these methods are that, if the capacitance or inductance of the wire changes along its path (such as from nearby metallic components on unshielded or untwisted wires, significant changes in the orientation or separation of the wire and its associated “ground” or paired wire, or discrete components added to the system), the capacitance or inductance of these additional effects will also be measured and will create errors in the length measurements. In addition, these methods are not suitable for locating faults on branched wires, as only the lumped capacitance or inductance is being measured. In spite of these limitations, these simple and inexpensive circuits can provide excellent location of open and short circuits on wires. They are ideally suited for integration in handheld test equipment (which has been done in our laboratory) and can provide an easy-to-use alternative to the manual search methods used today.

REFERENCES

- [1] NSTC, “Review of federal programs for wire system safety,” in *White House Rep.*, Nov. 2000.
- [2] C. Furse, Y. C. Chung, R. Dangol, M. Nielsen, G. Mabey, and R. Woodward, “Frequency domain reflectometry for on board testing of aging aircraft wiring,” *IEEE Trans. Electromagn. Compat.*, vol. 45, no. 2, pp. 306–315, May 2003.
- [3] C. Furse, Y. C. Chung, C. Lo, and P. Pendayala, “A critical comparison of reflectometry methods for location of wiring faults,” *Smart Struct. Syst.*, vol. 2, no. 1, pp. 25–46, 2006.
- [4] Y. C. Chung, C. Furse, and J. Pruitt, “Application of phase detection frequency domain reflectometry for locating faults in an F-18 flight control harness,” *IEEE Trans. Electromagn. Compat.*, vol. 47, no. 2, pp. 327–334, May 2005.
- [5] E. Edang, “Inexpensive ‘reflectometer’ locates an open circuit along a cable,” *Electron. Design*, vol. 49, no. 2, p. 115, Jan. 22, 2001.
- [6] R. Pallas-Areny and J. G. Webster, *Sensor and Signal Conditioning*. New York: Wiley, 1992.

- [7] D. Mariolo, E. Sardini, and A. Taroni, "Measurement of small capacitance variation," *IEEE Trans. Instrum. Meas.*, vol. 40, no. 2, pp. 426–428, Apr. 1991.
- [8] F. N. Toth and G. C. M. Meijer, "A low-cost, smart capacitive position sensor," *IEEE Trans. Instrum. Meas.*, vol. 41, no. 6, pp. 1041–1044, Dec. 1992.
- [9] M. Yamada, T. Takebayashi, S. Notoyama, and K. Watanabe, "A switched-capacitor interface for capacitive pressure sensors," *IEEE Trans. Instrum. Meas.*, vol. 41, no. 1, pp. 81–86, Feb. 1992.
- [10] D. M. G. Preethichandra and K. Shida, "A simple interface circuit to measure very small capacitance changes in capacitive sensors," *IEEE Trans. Instrum. Meas.*, vol. 50, no. 6, pp. 1583–1586, Dec. 2001.
- [11] J. C. Lotters, W. Olthuis, and P. Bergveld, "A sensitive differential capacitance to voltage converter for sensor applications," *IEEE Trans. Instrum. Meas.*, vol. 48, no. 1, pp. 89–96, Feb. 1999.
- [12] H. E. Green, "A simplified derivation of the capacitance of a two-wire transmission line," *IEEE Trans. Microw. Theory Tech.*, vol. 47, no. 3, pp. 365–366, Mar. 1999.
- [13] B. B. Wadell, *Transmission Line Design Handbook*. Norwood, MA: Artech House, 1991.
- [14] W. H. Hayt, *Engineering Electromagnetics*, 5th ed. New York: McGraw-Hill, 1989.
- [15] B. N. Das, S. B. Chakrabarty, K. Rao, and R. Siva, "Capacitance of transmission line of parallel cylinders in the presence of dielectric coating," *IEEE Trans. Electromagn. Compat.*, vol. 37, no. 1, pp. 94–96, Feb. 1995.
- [16] L. K. Baxter, "Capacitive sensors—Design and applications," in *IEEE Press Series on Electronic Technology*. Piscataway, NJ: IEEE Press, 1997.
- [17] National Semiconductor, *Application Note 72—The LM3900: A New Current-Differencing Quad of \pm Input Amplifiers*, Sep. 1972.
- [18] Fairchild Semiconductor, *Application Note 118*, Oct. 1974.
- [19] C. A. Holt, *Electronic Circuits: Digital and Analog*. New York: Wiley, 1978.
- [20] N. N. Amarnath, "Capacitance sensors for wire length measurement," M.S. thesis, Univ. Utah, Salt Lake City, UT, 2003.
- [21] R. J. Tocci and N. S. Widmer, *Digital Systems—Principles and Applications*. Englewood Cliffs, NJ: Prentice-Hall, 1998.
- [22] T. F. Bogart, Jr., *Linear Integrated Circuits: Applications and Experiments*. New York: Wiley, 1983.



Nirmal N. Amarnath received the M.S. degree in electrical engineering from the University of Utah, Salt Lake City, in 2004. His research focused on inexpensive methods for locating faults in electrical wiring.



Cynthia M. Furse (F'08) received the Ph.D. degree from the University of Utah, Salt Lake City, in 1994.

She is currently a Professor with the Department Electrical and Computer Engineering, University of Utah, Salt Lake City, teaching electromagnetics, wireless communication, computational electromagnetics, microwave engineering, and antenna design. She is also the Director of the Center of Excellence for Smart Sensors, University of Utah. The Center focuses on embedded antennas and sensors in complex environments, such as telemetry systems in the human body, and sensors for locating faults on aging aircraft wiring. She is also the Chief Scientist of LiveWire Test Labs, Inc., Salt Lake City, which is a spin-off company commercializing devices to locate intermittent faults on live wires. Since 1998, she has been directing the Utah "Smart Wiring" Program, which was sponsored by the Naval Air Systems Command and the U.S. Air Force.

Prof. Furse was a Graduate Fellow of the National Science Foundation Directorate for Computer and Information Science and Engineering and the IEEE Microwave Theory and Techniques Society. He was the recipient of the Professor of the Year Award from the College of Engineering, Utah State University, Logan, in 2000; the Faculty Employee of the Year Award in 2002; and the President's Scholarship at the University of Utah.



You Chung Chung (SM'03) received the B.S. degree in electrical engineering from Inha University, Incheon, Korea, in 1990 and the M.S.E.E. and Ph.D. degrees from the University of Nevada, Reno, in 1994 and 1999, respectively.

He has been a Research Assistant Professor of electrical and computer engineering with the University of Utah, Salt Lake City, and Utah State University, Logan, for four years. He is currently an Assistant Professor with the Department of Information and Communication Engineering, Daegu University, Gyeongsan, Korea. His research interests include computational electromagnetics, optimized antenna and array design, conformal and fractal antennas, smart wireless sensors, aging aircraft wire detection sensors, optimization techniques, electromagnetic design automation tool development, radio-frequency identification, and genetic algorithms.