



## Reflectometry for Structural Health Monitoring

Cynthia Furse

Department of Electrical and Computer Engineering, University of Utah, Salt Lake City, Utah 84112, cfurse@ece.utah.edu

**Abstract** Aging wiring and structural cables in buildings, aircraft and transportation systems, consumer products, industrial machinery, etc. are among the most significant potential causes of catastrophic failure and maintenance cost in these structures. Smart wire health monitoring can therefore have a substantial impact on the overall health monitoring of the system. Reflectometry is commonly used for locating faults on wire and cables. It can also be used for location of faults on structural cables, if they are electrically isolated. This chapter describes and compares several reflectometry methods -- time domain reflectometry (TDR), frequency domain reflectometry (FDR), mixed signal reflectometry (MSR), sequence time domain reflectometry (STDR), and spread spectrum time domain reflectometry (SSTDR) -- in terms of their accuracy, convenience, cost, size, and ease of use. Advantages and limitations of each method are outlined and evaluated for several types of aircraft cables, and the general equations that govern their performance are given. The impact of the fault location and size is also discussed.

**Keywords** aging wiring, fault location, reflectometry, time domain reflectometry (TDR), frequency domain reflectometry (FDR), standing wave reflectometry (SWR), mixed signal reflectometry (MSR), spectral time domain reflectometry (STDR)

### 1 Introduction

Reflectometry is a method that has been used for decades to locate faults on electrical wiring, to measure the electrical properties of materials, and in some limited applications, to measure the health of non-electrical structural components as well. Reflectometry transmits a high frequency signal (electrical, optical, acoustic, etc.) down the wire or cable under test. The signal reflects (echos) off impedance changes (breaks, faults, short circuits, etc.) in the cable. This reflected signal is received at the transmitter location. The time delay of the reflection is proportional to the distance to the fault, the magnitude of the echo is proportional to the magnitude of the fault, and the nature (shape, polarity, frequency spectrum, etc.) of the reflection tells the nature of the fault. There are several kinds of reflectometry including time domain reflectometry (TDR) 924-26 which uses a fast rise time step or pulsed signal, frequency domain reflectometry (FDR) 1314 which uses multiple sinusoi-



dal signals, sequence TDR (STDR) which uses pseudo noise, and spread spectrum TDR (SSTDR) which uses pseudo noise modulated onto a sinusoidal carrier signal for live testing with minimal interference with low frequency signals 34-37. Other methods include standing wave reflectometry (SWR), mixed signal reflectometry (MSR), and multicarrier reflectometry (MCR), all of which are related to FDR and use multiple sinusoidal signals on the wires. Noise domain reflectometry (NDR) utilizes existing noise on the wires as the effective test signal. 38 These methods are summarized in section 2. This chapter will be limited to electrical reflectometry, although other types of signals (optical and acoustic, for example), can also be used, and the theory applies in much the same way.

Reflectometry can be used in many applications. Most recently, great strides have been made in location of faults on aging electrical wiring for aircraft, and work is still very active in this area. These methods have also been applied to location of faults on anchors and metal-tensioning systems for pre-stressed concrete, with good success as long as the anchors are electrically isolated from the rest of the metallic structure (rebar, mesh grids, etc.).

Anchors for pre-stressed concrete (metal-tensioned systems) are used for construction and repair of foundations, retaining walls, and excavated and natural soil and rock slopes. At least one end of the cables is held together by a trumpet-shaped head. The other end may have a similar anchor head, or may be grouted into the cement foundation. The length of anchor cable between the two heads may be grouted (surrounded by cement) or ungrouted. Once installed, metal-tensioned systems are vulnerable to failure by corrosion of the metal elements, loss of anchorage, or both, but visual observations of the conditions at the element head assembly often do not indicate actual or potential problems, and cases of premature failure have already been documented.<sup>1</sup> Other methods for testing these cables include the lift off test (most common) which places a large strain on the cable (often using a crane) to see if the anchor remains intact. This method is expensive and difficult and may result in needless damage to the cable. It can also be used only for ungrouted anchors. Electrochemical tests (measurement of half-cell potential and polarization current) can be used to detect corrosion but do not give information on how much of the cable is corroded. Acoustic wave propagation methods such as impact (hammer) and ultrasound techniques have also been tested. For shorter anchors (10-20 feet), these may be useful. Attenuation and dispersion limit their use on longer cables. Electrical reflectometry has been shown to be feasible for testing anchors that are made of several steel cables, if they are electrically isolated. <sup>2</sup>

Location of faults on aging electrical wiring is also a key application of reflectometry in structures. Concerns over major aircraft disasters such as SwissAir 111 and TWA 800 have led to significant national commitment to find better ways to locate electrical faults before they have catastrophic consequences. 3-8 Over 90% of home fires are attributed to electrical faults, although it is not clear how many are due to installed wiring and how many to faulty plug-in consumer devices. 8 After the Space Shuttle Discovery disaster, the risk assessment determined that the wiring was more likely to fail than the tiles that did fail. 56 In addition to the safety problem, aircraft wiring systems are a maintenance burden. Wiring is pervasive in aircraft (e.g. 11 miles of wiring in an F-18C/D). One estimate is that between 1 million and 2 million man-hours are required at the operational level to troubleshoot and repair wiring system problems in the Navy alone each year. Highly trained technicians troubleshoot wiring problems using methods that are 40 years old. In fact, advances in avionics systems, such as Built-In-Test (BIT) may have hampered or even misled technicians if the fault turns out to be in the system wiring. Replacement of the complete wiring system in a typical aircraft is estimated to cost \$1-7 million, depending on the aircraft <sup>7</sup>.

Numerous federal programs have been devoted to developing methods for locating aircraft wiring faults <sup>8</sup>. Visual inspection, the most common traditional method, was determined to be insufficient. Time domain reflectometry (TDR), another traditional method for



locating faults, was observed to be accurate but difficult to use 9-12. Much of the recent work in reflectometry has been to develop better, more accurate algorithms for extracting fault information from reflectometry data as well as developing more accurate reflectometry methods. Alternatives to reflectometry are visual inspection of wiring systems (many/most faults are missed) and high voltage test systems (which can locate even small faults, but are very large and expensive and cannot be used on fueled aircraft) 9-12. Methods described in this chapter are suitable for use in handheld units or small sensors built into the structure itself, and some are suitable for continual or intermittent testing even on systems carrying other live electrical signals or in very electrically noisy environments. The methods discussed in this chapter are time domain reflectometry (TDR), frequency domain reflectometry (FDR), mixed signal reflectometry (MSR), sequence time domain reflectometry (STDR), spread spectrum time domain reflectometry (SSTDR), and noise domain reflectometry 13-17.

## 2 The Basics of Reflectometry

Reflectometry methods are among the most commonly used methods for testing wires. A high frequency electrical signal is sent down the wire, where it reflects from any impedance discontinuity. The reflection is received back at the transmitter, where the delay, magnitude, and nature of the reflection gives information on the location, size, and type of fault.

The reflection coefficient  $\Gamma$  gives a measure of how much signal is reflected from a fault or other impedance discontinuity (connectors, branches, etc.) and is given by

$$\Gamma = \frac{V_{reflected}}{V_{incident}} = \frac{Z_o - Z_L}{Z_o + Z_L} \quad (1)$$

where  $Z_o$  is the characteristic impedance of the transmission line, and  $Z_L$  is the impedance of the discontinuity. The characteristic impedances for typical aircraft cables are  $Z_o=50-200$  ohms, and most other electrical cables also are in this range. 39 The characteristic impedance of anchors in concrete is typically around  $Z_o = 75-300$  ohms. 2 The reflection coefficient for an open circuit ( $Z_L = \text{infinity}$ ) on any wire is 1, and the reflection coefficient for a short circuit ( $Z_L = 0$ ) is -1. A junction of two branched wires ( $Z_L = Z_o / 2$ ) has a reflection coefficient of -1/3.

Hard faults (open and short circuits, completely broken anchors, similar high reflection coefficient faults) are readily observable by reflectometry, but soft faults (damaged insulation, corroded anchors, other low reflection coefficient faults) are much more difficult to extract from the reflectometry signature. Because of the intense desire to locate faults before they impact the electrical system (prognostic health management, condition based maintenance, etc.), the interest in locating soft faults remains intense. Fig. 1 shows the raw, roughly sampled measured spread spectrum reflectometry (SSTDR) response for load impedances ranging from 20 to 2000 ohm for RG58 coax with characteristic impedance 50 ohms. (Other reflectometry methods will have the same relative peak heights, but different shapes.) The height of the peak relative to the maximum peak height gives the reflection coefficient. Impedance discontinuities that are greater than 10% are relatively easy to identify and locate just by looking at the response, or using relatively simple algorithms to automatically detect the response of the fault. Impedance differences below 10% become progressively more difficult to identify, as their response is much smaller, and eventually

the peaks from the reflection are smaller than the measurement error and cannot be detected. Reflections for damaged insulation on electrical cables or corroded anchors imbedded in concrete are virtually invisible from the original reflectometry signature. Locating these types of faults requires use of baselines and more advanced signal processing.

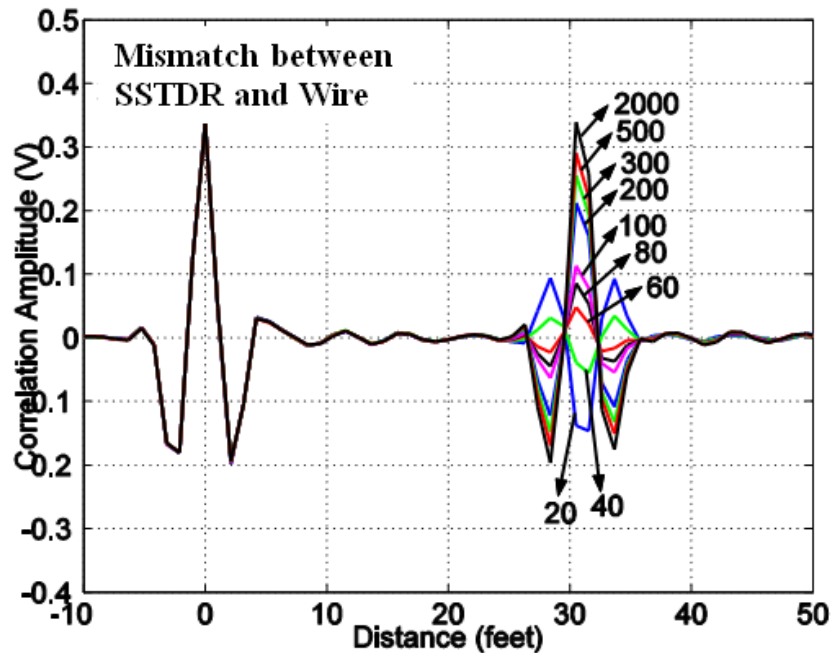

**Fig. 1.** Spread Spectrum Time Domain Reflectometry (SSTDR) responses for different load impedances on a 50 ohm RG58 coax that is 32 feet long. The correlation amplitude is proportion to reflection coefficient. Other reflectometry methods will have the same relative peak magnitudes, but different shapes of the pulses. From 39.

The delay between the incident and reflected voltages shows up in the location of reflectometry peaks. In Fig. 1, for instance, two sets of peaks are observed. The peak at 0 feet is from the reflection from the mismatch between the wire and test circuitry. The peak at 32 feet is from the load at the end of the wire. Reflectometry measures time delay. The distance  $L$  is the velocity of propagation divided by the time delay. The velocity of propagation in typical aircraft cables ranges from 0.5 to 0.8 times the speed of light, depending on the type of cable 1320. For anchors in concrete, this is slightly lower, typically 0.45-0.5 times the velocity of light. 2 It is therefore very important to know the type of wire or anchor being tested or to measure the velocity of propagation from a known length of the same cable in the same environment and configuration as you are testing. The velocity is dependent on the size and shape of the conductors, and therefore also depends on the distance between conductors. Many aircraft wires are bound together in bundles, often with several hundred wires in a bundle. The location of a specific wire within the bundle is not precisely controlled. Wires may meander through the bundle, sometimes near the center,



other times near the surface, creating a change in velocity of propagation of as much as 3%.  
39 Similar errors are observed if the wire is moved around between tests, even if it is closely paired with another wire (such as twisted pair or twin lead wire like lamp cord). 21

There are several sources of error in reflectometry measurements. The error in the hardware itself (typically on the order of 1% or even less) is likely to be the least of the problems. Ambiguity in the velocity of propagation translates is proportional to ambiguity in the location of the fault. The inability to see small reflections can cause a fault to be missed (fault negatives), or if the reflectometry is set too sensitive, false positives can result from normal impedance variations in the wire (proximity to other wires or metallic objects, water on the wires, connectors, bends, etc.) that can be as high or higher as the fault.<sup>40</sup> Another error is connection error. Since the reflectometer must be connected to a wide variety of cables or anchors, it is not generally feasible to match the impedance of the reflectometer with the wire. This means there will always be a reflection between the board and the wire being tested. The test-lead, connectors, adapters, etc. all add to this reflection in different ways. The physical connection to the wire is not always identical, particularly for handheld units. All of these types of errors can be handled by using baselines. The most accurate baselines can be expected from built in units, which can take continual baselines or baseline samples before/during/after significant changes (vibration of wires, water level changes in dams, etc.).

Another significant source of error in reflectometry methods is the so-called "blind spot". This is particularly problematic for wires or cables that are very short or when the fault is near the front of the cable. This is caused by the reflected signal overlapping the incident signal, because the time delay is so small. This makes it difficult to identify the reflected signal. Two methods can be used to reduce this problem. One is to use a longer test lead to connect the reflectometer to the wire under test. This would effectively delay the reflected signal enough that the overlap can be reduced or avoided. This may be practical for handheld applications, but it is not practical for in situ applications, where the reflectometer is actually imbedded in the system. Another method is to use a baseline identify the overlapping signals and extract the reflected response. 112122

With a basic understanding of reflectometry and the errors that are inherent in its use, the following sections describe several different types of reflectometry, each distinguished by the type of incident voltage used. Time domain reflectometry (TDR) uses a voltage step function. Frequency domain reflectometry (FDR) uses a set of stepped sine waves. Sequence time domain reflectometry (STDR) uses a pseudo noise (PN) sequence as the incident signal, and spread spectrum time domain reflectometry (SSTDR) uses a sine wave modulated PN code. Noise domain reflectometry (NDR) uses no signal at all, but rather only existing signal and its inherent noise on the wire. These methods will be compared for ease of use and interpretation, cost, size, ability to test live wires, and ability to analyze branched networks. The theoretical and practical accuracy are compared for each method.

A second class of sensors described in this paper are capacitance and/or inductance sensors. The capacitance of an open circuited cable and inductance of a short circuited cable are proportional to the length of the wire. Thus, if the capacitance (for open circuited wires) or inductance (for short circuited wires) can be measured, the length can be calculated. Several such methods have been tested 1823, and found to be very accurate for single lengths of wires. These sensors tend to be the least expensive circuits available for testing wires, however they are not able to detect faults on wire that are live, and they cannot test wires that branch into multiple arms or networks.

## A. Time Domain Reflectometry (TDR)

Time domain reflectometry (TDR) uses a short rise time voltage step as the incident voltage. 9-1226 For simple loads such as wiring, the reflected voltages are also step functions. As described above, the length of the cable can be calculated from the time delay between the incident and reflected voltages and the velocity of propagation ( $V_p$ ) of the cable. The magnitude and polarity of reflected voltage indicate the impedance (short, open, partial opens or shorts, etc.) at the discontinuity. The TDR response of a branched wire network is shown in Fig. 2, along with responses from other reflectometry methods. Steps in the response indicate reflections returned to the test point. The source of each reflection is marked on the figure.

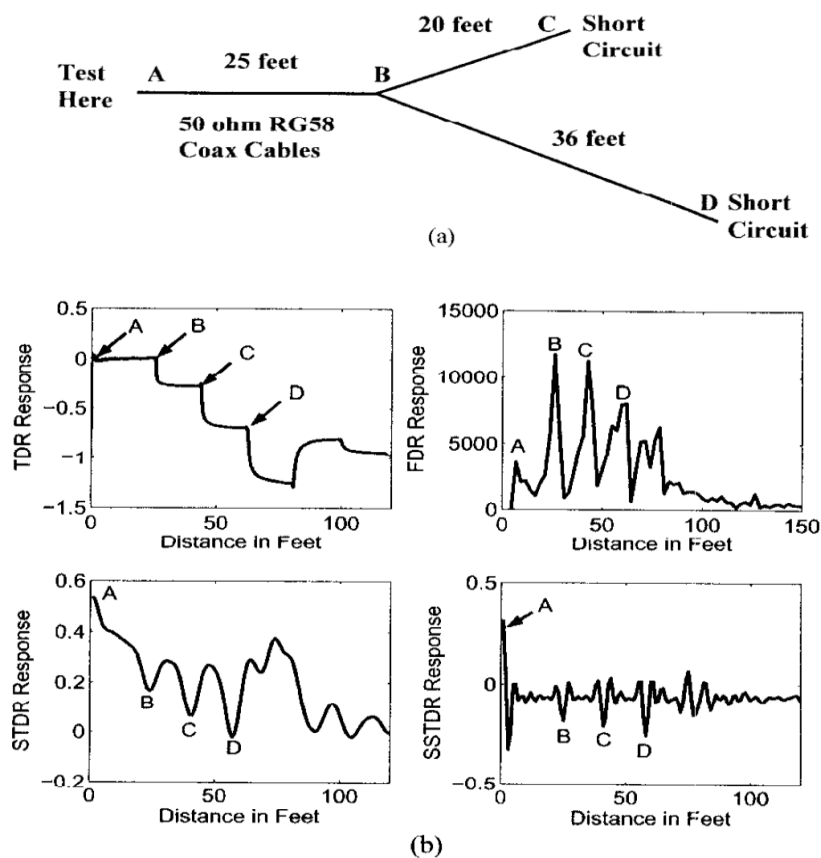

**Fig. 2.** (a) Network topology, (b) Reflectometry test signals of network shown (a) with TDR, FDR (MSR/SWR), STDR, SSTDR. From 39.

The accuracy of TDR is controlled by the rise time of the pulse and the sampling rate of the receiver. The TDR100 from Campbell Scientific was used in our tests. The TDR100



generates a 14 microsecond pulse and samples the reflected wave at 12.2 pico-second intervals. 26 The expected accuracy is 0.24 cm, for a typical cable with  $2/3$  the velocity of light. One problem that limits that accuracy of the TDR is that the voltage step contains a very broad frequency and disperses (spreads out) as it goes down the cable. It is difficult to know where to “read” this voltage step.

Due to the large bandwidth of most TDR devices, TDR has also been identified as a potential method for locating small anomalies such as frays or chafes if an extremely accurate initial baseline is available. 1112 There are both practical and theoretical reasons that obtaining a sufficiently accurate baseline to identify small anomalies is difficult or impossible. In practice, it would be very difficult (probably impossible) to obtain a baseline test of every wire that might go bad in a fleet of aircraft. Another problem of maintaining this baseline is that if the wire is moved, even a little, the small change in impedance and velocity of propagation can easily outweigh the even smaller reflection from the fray or chafe. This issue is analyzed in detail in 12 and 40.

It is difficult to control the problem of “blind spots” with this method, except by adding a length of cable to the test lead. This method has limited application on wires that are live. If the wire is carrying a low frequency signal (400 Hz power, for instance), it may be feasible to use TDR to test the wire while it is live. The TDR signal would need to be small enough to be below the noise margin of the existing signals. This creates a measurement problem for the TDR, as any noise (which may be as large or larger than the TDR signal) will corrupt the TDR trace. TDR is therefore not optimal for testing wires that are live. TDR may be used for testing wires with multiple branches, such as the one shown in Fig. 2. The limitation of this (and all) reflectometry methods is that the junctions and ends of the branched network all result in reflections and multiple reflections that show up in the reflectometry trace, but it is difficult to extract the network topology from the reflectometry trace. This has led to the reputation that “it takes a PhD to read a TDR”, which frankly extends to all reflectometry methods. Automatic methods for extracting the topology have achieved initial success 28. Thus, TDR is as capable of testing branched networks but requires an automatic network topology extraction algorithm to make it practical.

## B. Frequency Domain Reflectometry (FDR)

Frequency domain reflectometry (FDR) sends a set of stepped-frequency sine waves down the wire. There are three types of FDR that are commonly used in radar applications that are distinct in that they each measure a different sine wave property (frequency, magnitude, and phase) in order to determine distance. Related methods are also found in wire testing. These are Frequency Modulated Continuous Wave (FMCW) systems (which measure frequency shift), Phase Detection Frequency Domain Reflectometry (PD-FDR) systems (which measure phase shift) 13-15, and Standing Wave Reflectometry (SWR) systems (which measure amplitude or nulls of the standing wave).

### 1. Frequency Modulated Carrier Wave (FMCW)

Frequency Modulated Continuous Wave (FMCW) systems vary the frequency of the sine wave very quickly, generally in a linear ramp function, and measure the frequency shift between incident and reflected signals, which can be converted to time delay knowing the speed at which the frequency was ramped. This has not been implemented for wire testing, because of limitations on speed at which the frequency can be swept accurately and the accuracy at which the frequency shift can be measured 29.



## 2. Phase Detection Frequency Domain Reflectometry (PD-FDR)

Phase Detection Frequency Domain reflectometry (PD-FDR), shown in **Fig. 3 14**, measures the phase shift between incident and reflected waves. A voltage controlled oscillator (VCO) provides the sinusoidal signal that is stepped over a given bandwidth ( $f_1$  through  $f_2$ ) with a frequency step size  $\Delta f$ . A -10 dB sample of the incident sine wave is sent to the mixer, and the remainder is sent to the cable. The incident signal travels down the cable and reflects back from the load. The reflected wave is isolated from the incident wave by the second directional coupler and is sent to the mixer. The mixer multiplies the two sine waves, which gives signals at the sum and difference of the two frequencies input to the mixer. When they are at the same frequencies as they are in FDR, the difference at zero frequency (DC), and the sum is at double the original frequency. The DC voltage at the mixer output is the signal that the computer will detect and use to determine the length and load on the line. An analog-to-digital (A/D) converter used to read the mixer output effectively acts as a low-pass filter and removes the higher frequency components, The number of periods ('frequency') of the DC voltages collected over the injected frequency band is linearly dependent on the wire length. The Fast Fourier transform (FFT) of this collected waveform will give a Dirac delta function (single spike) at a location we will call *Peak*. The location of *Peak* in the FFT response is proportional to the length of the wire. The length is found from this peak index by: 14

$$L = 2L_{Max} \left( \frac{Peak - Peak(0)}{N_{FFT} - 1} \right) = \frac{1}{2} \left( \frac{Peak - Peak(0)}{N_{FFT} - 1} \right) \left( \frac{N_F - 1}{f_2 - f_1} \right) v_p \quad (2)$$

where,

*Peak* = location of the Dirac delta peak in the FFT (an integer value)

$v_p$  = velocity of propagation in the cable (m/s)

$f_1$  = start frequency of the FDR (Hz)

$f_2$  = stop frequency of the FDR (Hz)

$N_F$  = number of frequencies in the FDR = integer[  $(f_2 - f_1) / \Delta f$  ]

$\Delta f$  = frequency step size for FDR (Hz)

$L_{max}$  = maximum length shown below

Peak = Peak index for corresponding length in FFT

Peak(0) = Peak index for 0 length

$N_{FFT}$  = number of points in the FFT (an integer value, generally 1024, 2048, 4096 or 8192)

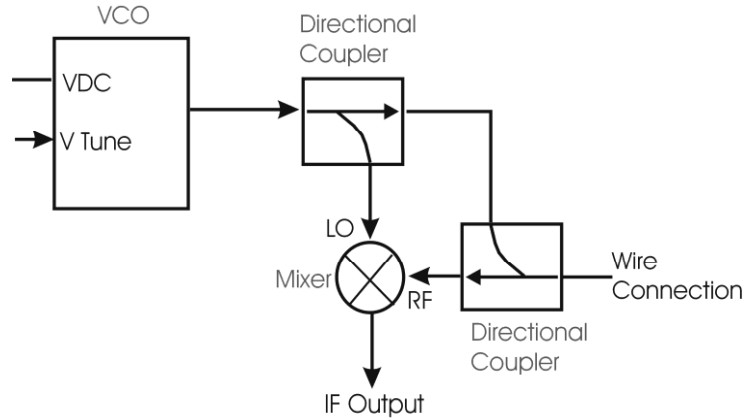

**Fig. 3.** PDFDR Block Diagram. © 2005 IEEE. Reprinted, with permission, from 39.

To improve the resolution of the results, the measured data can be zero padded. 30 The resolution (accuracy) of the measurements ( $\Delta L$ ) is given by 1314:

$$\Delta L = v_p / (2 N_{\text{FFT}} \Delta f) \quad (3)$$

The maximum length ( $L_{\text{max}}$ ) that can be measured is limited by the frequency step size and the Nyquist criterion:

$$L_{\text{max}} = \frac{v_p}{4\Delta f} \quad (4)$$

A sample set of responses of different lengths of a shielded twisted pair M27500-24SE2S23 wire is shown in **Fig. 4(a)**, and their FFTs are shown in **Fig. 4(b)**. The peak location in the FFT is substituted into equation (2) to find the wire length. The velocity of propagation is 0.66 times the speed of light for this wire 1314.

Automatic analysis is quite easy with FDR methods, so they are relatively easy to use. Unlike TDR, very little frequency dispersion is seen in this method, as it is not generally as broad band as TDR, and the peak locations are clearly visible. PD-FDR is also capable of measuring branched networks of wires, where a peak in the FFT would be observed for each reflection and multiple reflections in the network, such as the response shown in **Fig. 2**. The same limitation that this does not directly provide the network topology exists as for TDR. FDR methods can be used on live wires, provided that the test frequencies are not within the frequency range of the existing signal on the wire, and that the FDR is below the noise margin of the signal. It is not optimal for live wires, however, as noise from the existing signal can provide significant corruption of the FDR response that may or may not be effectively filtered by the FFT. Analysis of short wires requires special treatment to remove the low frequency associated with the short connection between the PD-FDR board and the cable under test. 1113141822 This is similar to the blind spot in TDR.

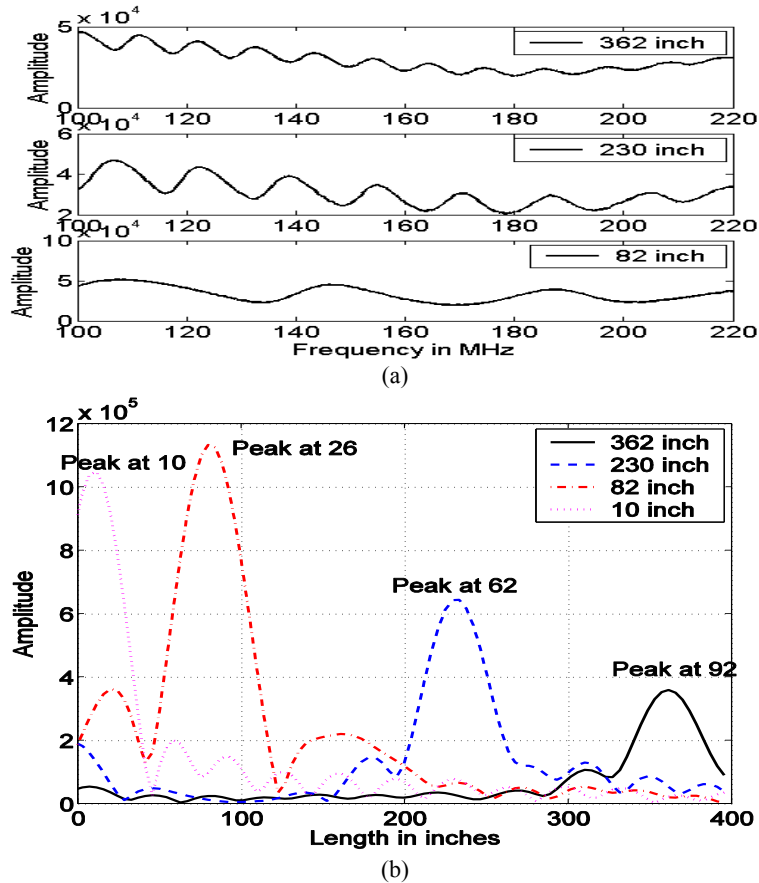

**Fig. 4.** PD-FDR results for open circuited RG58 50ohm coax. (a) DC output of the mixer as a function of stepped frequency, and (b) the Fourier transform of the results in (a) with  $N_{FFT} = 2048$ . The reduction in height is caused by the attenuation on the wire. © 2003 IEEE. Reprinted, with permission, from 39.

### 3. Standing Wave Ratio (SWR)

Standing wave ratio (SWR) systems measure the magnitude of the standing wave created by the superposition of the incident and reflected signals on the wire. The sum of these two sine waves will have a series of peaks that are caused by their constructive interference and nulls caused by destructive interference. As the frequency is swept, these nulls can be identified (as described in section 3a) or the pattern of the standing wave is proportional to the response obtained from the PDFDR (as described in section 3b). The frequency must be swept through multiple nulls, because otherwise wires that are multiples of a wavelength are indistinguishable. The two types of SWR are described below 3233.



### a. Null Detection

For null detection SWR, the frequency is stepped until a null in the standing wave is observed, and from this, the distance to fault is found. SWR has accuracy similar to the PD-FDR described above for hard faults (open and shorts) where the incident and reflected signals are approximately the same magnitude (the reflected wave will be somewhat less, depending on the attenuation on the line, but for frequencies in the kHz range where the SWR is currently implemented, this is negligible for most types of aircraft cable). When the fault is not an open or short, however, the magnitude of the reflected wave is reduced and overshadowed by the incident wave, which makes the nulls in the standing wave less pronounced and therefore less accurate to measure. This effectively limits the SWR to hard faults. SWR also cannot be used for branched networks, as the standing wave is made up of the incident plus several reflected waves, thus making it more complex. If the magnitude of the wave was measured at every frequency, the multiple reflections could, in theory, be extracted. This is what the Mixed Signal Reflectometry system described next does.

SWR devices are relatively small and inexpensive, requiring only a sine wave generator (generally a voltage controlled oscillator), a received signal strength indicator (RSSI) chip, and some basic control circuitry. These devices could be integrated into a single chip, and would be feasible to integrate within the wiring system itself. This type of SWR system has been implemented in handheld wire testing systems 3233.

### b. Magnitude Detection -- Mixed Signal Reflectometry (MSR)

A Mixed Signal Reflectometer (MSR), shown in Fig. 5, is like a PD-FDR without the directional couplers (thus saving sizeable expensive) or an SWR that measures the squared magnitude of the standing wave for all frequencies (thus improving accuracy, especially for smaller reflections). Like the PDFDR, a voltage controlled oscillator (VCO) provides a sinusoidal signal that is stepped over a given bandwidth ( $f_1$  through  $f_2$ ) with a frequency step size  $\Delta f$ . It reflects back and is superimposed on the incident wave. The combination of the incident and reflected waves (standing wave) goes through the attenuator, which reduces the amplitude of the signal to prevent overloading the mixer. The attenuated signal feeds into both inputs of the mixer. The output of the mixer is the square of the sum of the incident and reflected signals 15:

$$\begin{aligned} & \{B[\sin(\omega t) + \alpha \sin(\omega t + D)]\}^2 \\ &= B^2 \left\{ \left[ \frac{1}{2}(1 + \alpha^2) + \alpha \cos(D) \right] + \left[ \frac{1}{2} \sin(2\omega t) + \alpha \cos(2\omega t + D) + \frac{1}{2} \sin(2\omega t + 2D) \right] \right\} \end{aligned} \quad (5)$$

where

$\alpha$  : attenuation

$\tau$  : signal delay from the wire

$\omega$  : frequency of VCO output,

A : amplitude of the VCO output

$B$  : amplitude of the sinusoidal wave after reflection and attenuation.

This contains the first harmonic of the sine wave and a DC value,

$$B^2 \left[ \frac{1}{2} (1 + \alpha^2) + \alpha \cos(D) \right] \quad (6)$$

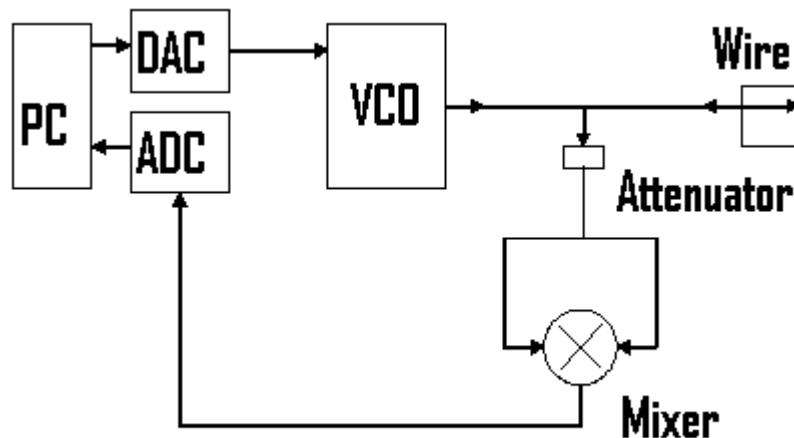

**Fig. 5.** MSR Circuit Diagram. © 2003 IEEE. Reprinted, with permission, from 39.

This DC value is the same as for the PD-FDR, such as shown in **Fig. 4**. The mixer output goes into a digital to analog converter, which automatically filters out the high frequency component. The DC values as a function of frequency are a sinusoidal wave whose frequency is linearly proportional to the wire length, virtually identical to the FDR responses shown in **Fig. 4**. The MSR is more accurate than the SWR for small reflections, however this advantage has not been found to have practical application, as it still cannot analyze the very small anomalies associated with frays or chafes. MSR is less expensive and smaller than PD-FDR, since it does not require the directional couplers. For branched networks, the MSR response includes the multiple reflections plus their sums and differences, which makes its response more complex to calculate than the PD-FDR branched network response. Limitations on the use of MSR for live wires and short length wires are virtually identical to those for PD-FDR.

The MSR system is less expensive than either the PD-FDR or SWR. It requires only a voltage controlled oscillator (VCO), mixer, and related control circuitry.

#### D. STDR/SSTDR

Block diagrams of Sequence Time Domain Reflectometry (STDR) 1617 and Spread Spectrum Time Domain Reflectometry (SSTDR) are shown in **Fig. 6** 1734. STDR uses a pseudo noise (PN) code as the test signal, as shown in **Fig. 7(a)** 1734. The PN signal can be very, very small compared with the aircraft signal on the wire (-20 dB down, for in-

stance) and is well below the allowable noise floor of the aircraft signal shown in Fig. 7(a) and (b) 1734. Although the PN code magnitude is small, it is relatively long (1023 bits, for example) and has a distinct and recognizable pattern. The correlation responses of STDR and SSTDR are shown in Fig. 7(c) and (d) 1734. The signal at the source end (a combination of incident and reflected waves) is correlated with a test copy of the PN code. Correlation delays, multiplies, and sums the signal with the test PN code. When the codes are synchronized, a high value is obtained, and when the codes are not synchronized, a low value is obtained. The correlation enables STDR to run on live wires far better than any of the other reflectometry methods described so far. The length of the wire (distance to fault) is easily determined from the correlation data, as shown in Fig. 2.

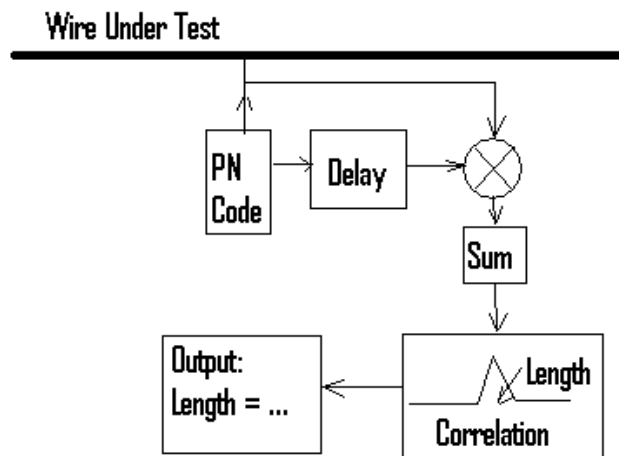

**Fig. 6.** Sequence (STDR) Test System. For SSTDR, the input signal is a sine wave modulated PN code. From 39.

A slight change to the STDR signal gives even better performance for live wires or for anchors requiring extremely accurate testing. Spread Spectrum Time Domain Reflectometry (SSTDR) uses a sine wave modulated PN code as the test signal, as shown in Fig. 7(b). The correlation peak obtained is sharper than the STDR peak. This method is very efficient and accurate for live wire testing, and has been shown to be accurate with the existing data signal 50 dB greater than the SSTDR signal. This is because the spectrum of the SSTDR signal is outside of the spectrum of the data signal. 34

Height of the peaks used to determine the wire length for the S/SSTDR system relative to the noise floor depend on the speed, length, type, and integration time of the PN code 27. The system shown here uses a PN code of length 127 with a frequency of 58 MHz. The accuracy of the S/SSTDR system is controlled by the distance between subsequent samples of the correlation peaks, which is controlled by the precision of the shifter in the correlation step. A time shift of  $T$  gives a distance error of  $\Delta L = (\text{velocity of propagation})(T/2)$ . If only individual chips are correlated (as opposed to “subchips”), the accuracy is insufficient for this application). For our system, subchip sampling at a rate of 10 samples per chip is required to obtain a resolution of 17 cm. This error can be substantially reduced (to about 3 cm) by fitting a curve to the correlation peaks to more precisely locate peaks that are missed by sparse correlation sampling. 21 S/SSTDR has been demonstrated for location of



intermittent faults that are less than 2ms in duration. Both wet and dry intermittent arcs can be located with this method.

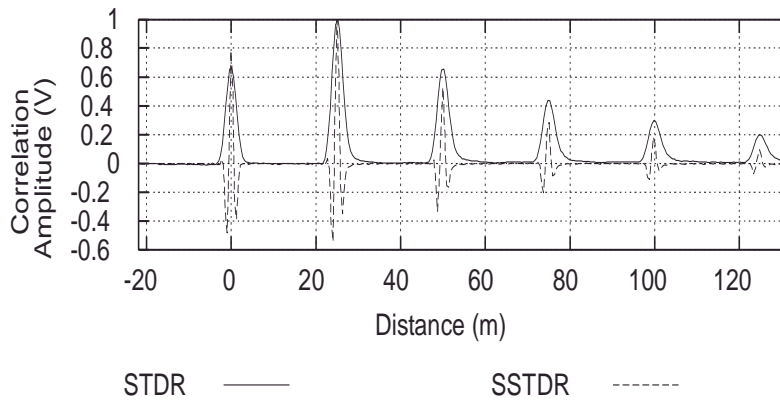
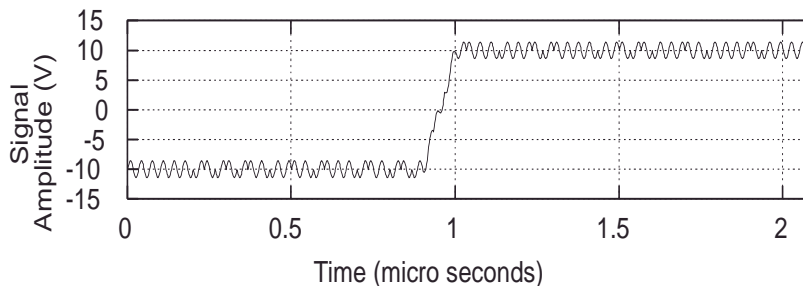
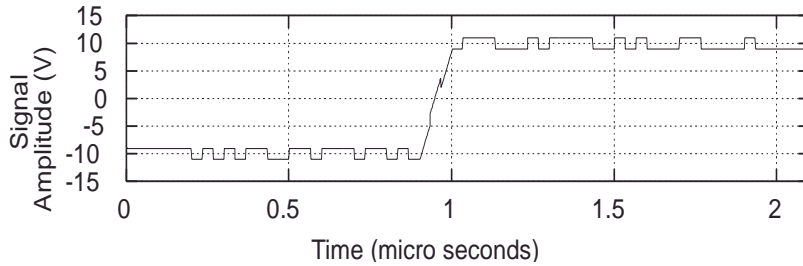

**Fig. 7.** STDR and SSTDR signal added to a 10 V RMS signal at 30 MHz. The S/SSTDR signals are a Maximum Length (ML) Code 1V RMS at 58 MHz, with a 58 MHz sine wave modulation in the case of SSTDR. The magnitude of the S/SSTDR signals can be much smaller than shown here, depending on the signal on the wire. (a) STDR Signal (b) SSTDR



Signal (C) Correlation response of STDR and SSTDR for a wire that is open circuited on the end. © 2005 IEEE. Reprinted, with permission, from 39.

The S/SSTDR system has several advantages over other types of reflectometry systems. First, since it can run very well on live wires, it can create and store its own dynamic baseline. Base lining is done to determine when something in the wiring system has changed. A baseline shows when the wire is “good”, and the difference from the baseline shows where the fault has occurred. Base lining is a serious limitation of reflectometry systems today. Even if a baseline could be taken for every wire in a plane, the vibration and normal changes within a plane would corrupt this baseline so much that it would not be very useful later when a fault occurred, as discussed in the TDR section. The SSTDR system eliminates this problem and locates changes within a wiring system, using a dynamic baseline that it creates itself. There is still one unresolved issue about S/SSTDR base lining. Loads with time-varying impedance (such as equipment being turned on and off) will show up as changes to the baseline, and these changes need to be distinguished from real faults. It would be relatively simple to ignore all changes at the location of the load; however this would mean that a fault at the connection point to the load would be missed. Additional information would be needed to make this distinction, such as an additional sensor placed at the load, connection to the control system for the load indicating when changes were expected (and could therefore be ignored), or distinction between the fault and load change signatures (similar to an arc fault circuit breaker).

Perhaps the most significant advantage of the SSTDR system is that since it is testing while the wires are live, the small “arc faults” or other intermittent faults are actually open or short circuits (“hard faults”) for a short duration of time (a few ms or less). After their intermittent event, the fault is often a “soft fault” with an impedance discontinuity that is too small to locate. The important aspect of intermittent fault location is to test the wire while the fault occurs, and the SSTDR system is the only method that we know of that can test the wire while it is live without interfering with it. 16

Another advantage of this method is that it can be made extremely accurate by lowering the noise floor of the test system. This can be done several ways including increasing the length of the PN code or increasing the number of times it is run and averaged before a reading is confirmed. The tradeoff here is that the longer you test, the longer an intermittent fault must be in order for you to find it. The low noise floor has allowed testing of extremely long cables such as the 8500 foot long triple core, 350 MCM subsea cable shown in **Fig. 8**. A short circuit was located on this cable at 6900 feet with a 1.5 MHz SSTDR signal and confirmed when it was located by repair divers. [41]



**Fig. 8** 3 core, 350 MCM sub sea cable

The S/SSTDR is capable of being miniaturized into a mixed signal IC, which will make it very small and likely the least expensive reflectometry system available. It is very feasible to consider imbedding this system in the wiring system. S/SSTDR is capable of analyzing branched networks, with the same limitations as FDR and TDR, that the network topology must be extracted from the multiple peaks in the reflection data.

### **E. Noise Domain Reflectometry (NDR)**

Noise Domain Reflectometry (NDR) 38 uses existing data signals on wiring and does not need to generate any signals of its own. There are two types of NDR, type I (where incident and reflected signals are separated) and type II (where they are superimposed). NDR is totally "quiet" and passive to other signals on the media. NDR functions very similar to spread spectrum methods by utilizing correlation to determine the length of the wire. However, unlike spread spectrum methods that require a PN code as the test signal, any significant noise or high speed signal on the line can be used to passively test the wire and locate the distance to a fault. The family of Noise Domain Reflectometers (NDR) utilizes the properties of time domain autocorrelation functions and can be used to determine individual time delays or multiple reflections such as from branched networks. The advantage of using NDR over other forms of reflectometry is that there is no need to transmit a specific test signal. Instead, the existing signal or noise on the wire is used as the test signal. In other words, NDR can be totally "quiet" to other users of the media being tested. Thus, NDR may be ideal for applications where data integrity is critical such as in flight "live" wire fault location for aging aircraft wiring or applications where stealth is desired.

## **4 Comparison of Reflectometry Methods**

There are several features on which we could compare reflectometry methods, which will be summarized here. A number of comparisons have been made, including 39, for specific applications, types of equipment, etc.



The accuracy of all reflectometry methods is controlled by their useable bandwidth. The higher the bandwidth, the greater the accuracy. The useable bandwidth is decreased (often substantially and sometimes critically) by attenuation in the system being tested. High frequencies are attenuated more than lower frequencies, so FDR, STDR, SSTDR, etc. are normally chosen to be below the range of attenuation for the type and length of cables being tested. TDR data is smoothed by high frequency attenuation (sharp rise on the front of the steps disappear), thus making it much harder to read accurately. Bandwidth is not limited by the reflectometry method itself. It is limited by the test system and the engineering choices associated with the design of each specific instrument.

The accuracy of the method is also controlled by the algorithm and methods used to extract the data. No algorithm can extract information where this is none to be extracted, so the bandwidth and frequency range must first be suitable to the application. Knowledge of the velocity of propagation, base lines that provide the expected wire system and configuration, etc. are all used to improve automatic fault location algorithms. This is an area of active research, and many new algorithms and methods are emerging.

Another major consideration when selecting a reflectometry system is its application. If you are interested in finding intermittent faults, for example, you will need to be actively testing at the instant the intermittent fault asserts itself. Systems that can be integrated into the existing electrical system or structure can provide the advantage of continually updated base lines, continual monitoring, and collection of system health information over time. This is typically more accurate than occasional testing with handheld systems. If the electrical system is live or if the environment has a lot of coupled electrical noise, the reflectometry systems needs to be compatible with the existing signals so neither interferes with the other. STDR and SSTDR have been designed for location of intermittent faults on live wires, and are ideal for that application. NDR may be an option for the most sensitive applications if they have sufficiently high noise or signals already on the wires. Other methods must be specifically tailored so that they are out of the band of the existing signals, which may or may not be possible. The broader band the reflectometry test system, the more difficult that is to accomplish.

## 5 Testing Concrete Anchors with S/SSTDR<sup>1</sup>

This section describes the use of S/SSTDR for location of a partial corrosion on a multi-stranded anchor for pre-stressed concrete. In order to determine the feasibility and accuracy of this method, stranded cables were buried in trenches filled with sand, deliberately damaged in a controlled fashion, and tested to determine if this damage could be detected and located. The particular challenge for this application is the attenuation of the cable, which makes the reflection from the distant end of the cable and any faults appear very small indeed by the time they return to the sending end. This was overcome using the STDR method and averaging the tests over a relatively long period of time (seconds). This significantly reduces the measurement noise of the method, thus enabling location of very small reflected signals. A baseline was taken prior to damaging the anchor. The sensor was not disconnected between tests, thus emulating the effectiveness of a built-in test system.

Fig. 9 shows the cross section of a simulated anchor used for the sand tests described in this section and the definitions of wire, strand, and anchor. It is important to note that the anchors must be electrically isolated from the surrounding metal in the dams. This depends on the construction method by which they were installed. If the anchor heads are connected

---

<sup>1</sup> This section is reprinted from [2] with permission. (© 2009 IEEE)



into the rest of the rebar in the dam, then an isolating material is needed between the anchor head and its support.

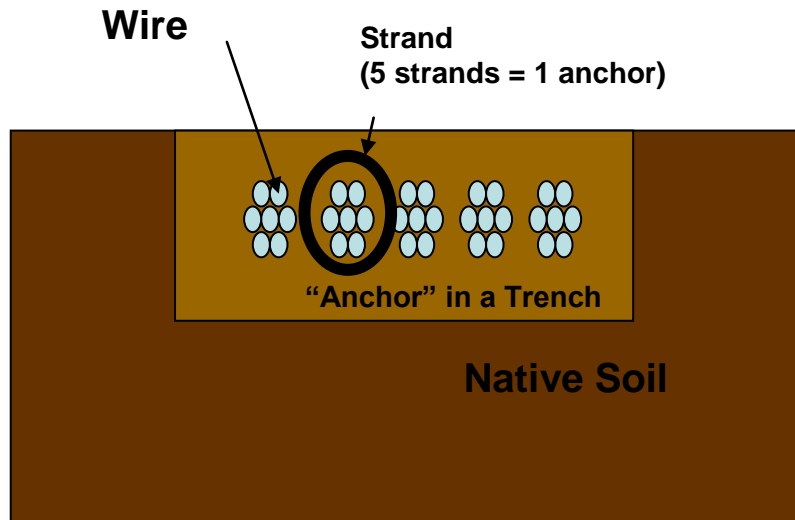

**Fig. 9.** Cross Section of Simulated Anchor for this Test. Another identical anchor in another trench a few feet away was used as the 'ground' reference. © 2009 IEEE. Reprinted, with permission, from 39.

A test bed was created at the Bureau of Reclamation in Denver, Colorado. The test bed consisted of four parallel 200' trenches (each 2' wide and 2' deep), as shown in Fig. 10. Each trench was filled with 1' of sand, and then five strands of 5/8" 7-wire cable were placed in parallel. Each strand was held apart by a plywood spacer to ensure that they did not touch along the length of the anchor as shown in Fig. 11.

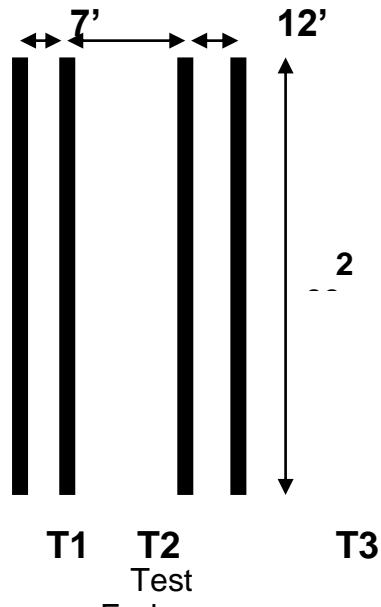

**Fig. 10.** Four parallel trenches were used simulate anchors in concrete. © 2009 IEEE. Reprinted, with permission, from 39.



**Fig. 11.** (Left picture) Ends of two anchors extending from trenches 1 (left) and 2 (right), 7' apart. This shows the plywood spacers used to hold the strands approximately 4" apart in the trenches, as shown in the right photo. © 2009 IEEE. Reprinted, with permission, from 39.

In order to simulate the normal configuration where multiple strands are short circuited together at the anchor head to create a single anchor, the five strands in each trench were

tightly held together with duct tape as shown in Fig. 11 (left picture). An STDR handheld test unit produce by LiveWire Test Labs was connected to the simulated anchors with approximately 10-20' of 12 gauge copper wire (available from typical home improvement centers), depending on the distance to each trench being tested. A metal pipe clamp was used to connect the 12 gauge wire to the bundle of strands representing the anchor, as shown in Fig. 11. In order to speed up collection of test data from multiple trenches, wires were run to each trench, and then connected individually to the STDR, connecting and disconnecting sequentially during each data collection. Fig. 12 shows the connection of the STDR to the simulated anchors in trenches 3 and 4. Care was taken to minimize the coils or loops in the 12 gauge (green) connection wires. (Left photo) 12 gauge wires were connected to the 90 ohm coaxial cable using a banana-to-BNC connector as shown in the right photo. Testing on subsequent days was simplified by soldering banana plugs to the 12 gauge wires, so they could be simply plugged into the banana jacks.



**Fig. 12.** Connection of STDR to simulated anchors in trenches 3 and 4. Care was taken to minimize the coils or loops in the 12 gauge (green) connection wires. (Left photo) 12 gauge wires were connected to the 90 ohm coaxial cable using a banana-to-BNC connector as shown in the right photo. Testing on subsequent days was simplified by soldering banana plugs to the 12 gauge wires, so they could be simply plugged into the banana jacks. © 2009 IEEE. Reprinted, with permission, from 39.

Damage to the anchors was simulated by cutting them with an oxygen acetylene torch. An example of these cuts are shown in Fig. 13. Fig. 13 (a) shows five strands completely cut and pulled away from each other. (b) shows strands that were cut and not pulled away from each other. Pull tests (described later) were done to determine the spacing in (b) that was detectable.



(a)



(b)

**Fig. 13.** Simulated Damage. (a) shows five strands completely cut and pulled away from each other. (b) shows strands that were cut and not pulled away from each other. Both fault types gave similar results. © 2009 IEEE. Reprinted, with permission, from 39.

For each test, an initial test (baseline) was taken when the wires were 200 feet long. This baseline, which is different for each trench, was used as the baseline for all future tests of that trench. In practice, this baseline represents the sampled data that a dam operator would have taken when the dam was new (this is optimal), or partially aged (which should still be functional). Any change from this baseline represents a change in the impedance of the anchor being measured and indicates a break or possible damage. Because of the highly lossy nature of the soil (or concrete) surrounding these anchors, the reflectometry peak that would normally be used to locate the end of the cable was not readily visible beyond a few feet. Thus, it was only possible to locate breaks on cables up to about 10' away just by examining the response (not using a baseline). Breaks beyond this distance required use of a baseline taken before the damage occurred. Also, we attempted to use one trench as a baseline for another but found that this was not functional. There was more change between trenches than from the small changes we were seeking. Thus, the only functional method for locating breaks that were more than 10' from the test end was to use a baseline approach that would require in situ sensors testing at continuous intervals over time.

Location of a break in the anchor was done by testing the wires when they were all 200' long (collecting this data as a baseline), cutting one of the anchors (all 5 strands, in this case), retesting, and subtracting the new test data from the original baseline. The differences for several break locations are shown in Fig. 14 for anchors 7' apart. For anchors that are 12', 19', and 26' apart, the peaks are progressively smaller and the noise larger. Based on these tests using a baseline, a complete break in the cable can be seen for anchors that are 7', 12' and 19' apart up to 160 feet and 26 feet apart up to about 140'. Breaks further away than these MAY be detectable with future improvements.

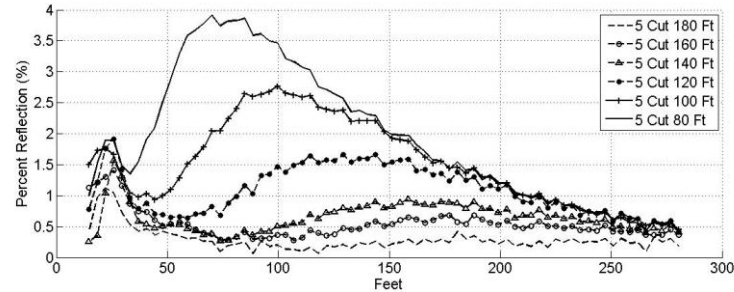

**Fig. 14.** Location of breaks in anchors that are separated by 7'. © 2009 IEEE. Reprinted, with permission, from 39.

In order to simulate a partially corroded (or partially broken) anchor, each of the five strands were cut one at a time and pulled physically apart from the other parts of the cable so there was no possibility of electromagnetic coupling to the other parts of the cable. Smaller breaks were also tested, and found to be virtually identical to those that were pulled well apart. Partially Damaged Anchors showing effect of cutting 1,2,3,4 or 5 strands are shown in Fig. 15 for anchors 7' apart. For cuts up to 160' it appears that partial damage to the anchor can be identified. As for anchors that are fully cut, increasing the separation between anchors reduces the sensitivity of the method. It should also be noted that the strands in these tests were separated by wooden spacers, representing the configuration where multiple strands are separated in space. Other types of anchors have all of the strands touching or bundled together. These types of anchors were found to have reflectometry responses that were significantly less sensitive to partial damage.

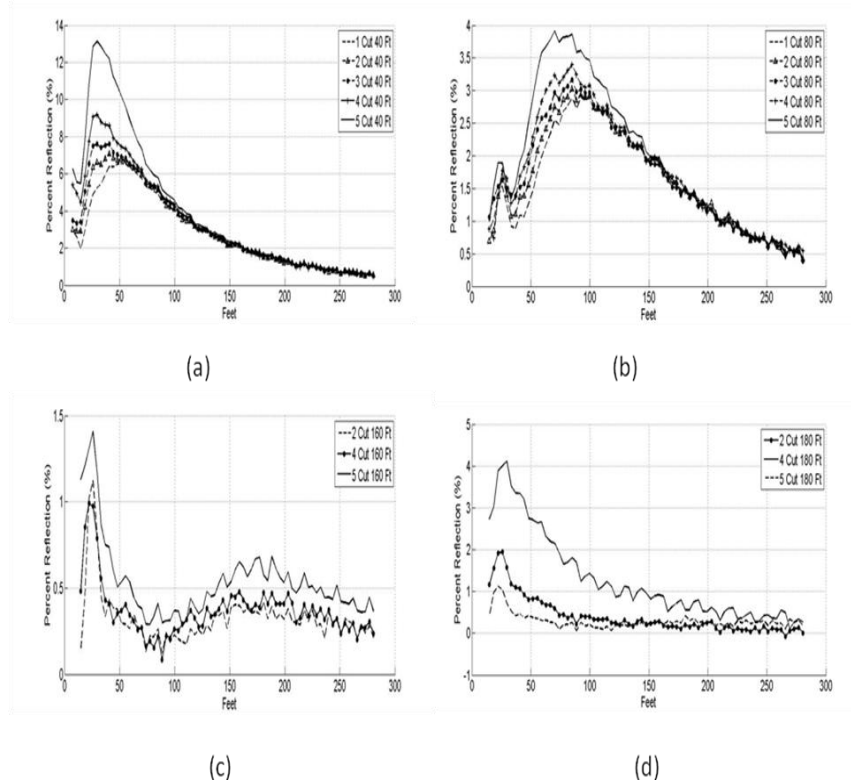

**Fig. 15.** Partially Damaged Anchors showing effect of cutting 1,2,3,4 or 5 strands. (a) Cuts at 40', (b) cuts at 80', (c) cuts at 160', (d) cuts at 180'. All data is compared to a baseline at 200'. All anchors are in trenches 7' apart. For cuts up to 160' it appears that partial damage to the anchor can be identified. © 2009 IEEE. Reprinted, with permission, from 39.

## 6 Discussion

This chapter compares several types of reflectometry methods for structural health monitoring. Reflectometry methods transmit high frequency signals on a wire or structural metallic element (an anchor used for pre-stressed concrete, for example). These signals reflect off impedance discontinuities on the wire or cable, and are received at the transmitter location. The time delay, magnitude, and nature of the reflections tell the distance to the fault, the magnitude of the fault, and the type of the fault, respectively. There are numerous types of reflectometry methods, each using a different type of transmitted signal. This chapter described electrical reflectometry methods, but many of the same principles apply when using optical or acoustic reflectometry systems.

Smart imbedded test systems for wiring hold the promise of revolutionizing the way large wiring systems are designed and maintained and may also be used for structural health monitoring. The ability to precisely identify and locate faults on wires and cables remotely enables monitoring, diagnosis, control, and potentially even prognosis of degrad-



ing systems. Critical elements including sensors that are small enough to be imbedded, that are capable of locating faults on live or noisy systems, and that can be used on branched networks are all rapidly emerging and are showing excellent results.

Aging wiring and cable systems have plagued us for decades, and the proliferation of electronic systems within our society is further propagating that problem. Test methods to locate faults, or to locate early intermittent predecessors to catastrophic faults, can dramatically decrease the maintenance cost and time burdens as well as improve safety. Handheld systems are rapidly emerging, and systems that can be used on live wires are following close behind. These new methods promise a dramatic shift in electrical maintenance and open up opportunities for robust and inexpensive imbedded structural sensors that have not previously existing.

## References

1. Withiam, J., Fishman K, Gaus M (2002), Recommended practice for evaluation of metal-tensioned systems in geotechnical applications, National Research Council Transportation Research Board, National Highway Cooperative Research Report #477, National Academy Press, Wash DC, 2002
2. Furse C, Smith P, Diamond M (2009), Feasibility of Reflectometry for Nondestructive Evaluation of Prestressed Concrete Anchors, IEEE Journal of Sensors, Vol. 9. No. 11, Nov. 2009, pp. 1322 - 1329
3. Furse C, Haupt R (2001), Down to the Wire: The Hidden Hazard of Aging Aircraft Wiring, IEEE Spectrum, Feb. 2001, pp.35-39.
4. NASA (2000), Wiring Integrity Research (WIRE) Pilot Study AOSP-001-XB1, August 2000.
5. Lloyd R (1999), 64 cases of wiring problems found on shuttle fleet, CNN Reports, Sep. 3, 1999 <http://www.cnn.com/TECH/space/9909/03/shuttle.repairs/>
6. Lloyd R (1999), NASA delays shuttle launch to inspect wiring, CNN Reports, Aug. 13, 1999, <http://www.cnn.com/TECH/space/9908/13/shuttle.update/>
7. Conley T (2003), The relationship among component age, usage (reliability) and cost of naval aviation repairables, Aging Aircraft Conference 2003, New Orleans, Sep. 2003
8. NSTC (2000), Review of Federal Programs for Wire System Safety, White House Report, Nov. 2000.
9. Steiner J, Weeks W (1990), Time-Domain Reflectometry for Monitoring Cable Changes: Feasibility Study, EPRI GS-6642, February 1990
10. Waddoups B (2001), Analysis of reflectometry for detection of chafed aircraft wiring insulation, MS Thesis, Utah State University, Logan, Utah, 2001 (all theses and dissertations in this paper can be obtained from: [www.lib.umi.com](http://www.lib.umi.com))
11. Schmidt M (2002), Use of TDR for Cable Testing, MS Thesis, Utah State University, Logan, Utah, 2002.
12. Jani A (2003), Location of Small Frays using TDR, MS Thesis, Utah State University, Logan, Utah, 2003
13. Furse C, Chung Y, Dangol R, Nielsen M, Mabey G, Woodward R (2003), Frequency Domain Reflectometry for On Board Testing of Aging Aircraft Wiring, IEEE Trans. Electromagnetic Compatibility, pp.306-315, May 2003.
14. Chung Y, Furse C, Pruitt J (2005), Application of Phase Detection Frequency Domain Reflectometry for Locating Faults in an F-18 Flight Control Harness,



- IEEE Trans. Electromagnetic Compatibility, IEEE Trans. EMC, Vol. 47, No.2, May 2005, pp. 327 - 334
15. Tsai P, Lo C, Chung Y, Furse C (2003), Mixed signal reflectometer for location of faults on aging wiring, IEEE Sensors Journal, Vol.5, No. 6, Dec. 2005, pp. 1479-1482
  16. Furse C, Smith P, Safavi M (2005), Feasibility of Spread Spectrum Reflectometry for Location of Arcs on Live Wires, IEEE Sensors Journal, Vol.5, No. 6, Dec. 2005, pp. 1469-1478
  17. Furse C, Lo C, Chung Y, Pendayala P, Nagoti K (2005), Spread Spectrum Sensors for Critical Fault Location on Live Wire Network Structures, Journal of Structural Control and Health Monitoring, Vol 12, 2005, pp. 257-267
  18. Chung Y, Amarnath N, Furse C (2009), Capacitance and Inductance Sensors for Open and Short Ends Circuit Wire Faults Detection, IEEE Trans. Instrument and Measurement, Vol. 58, No. 8, Aug 2009, pp. 2495-2502
  19. Iskander M (1992), Electromagnetic Fields and Waves. Englewood Cliffs, NJ: Prentice Hall, 1992.
  20. White E (2004), Personal Communication, 4/13/2004
  21. Pendayala P (2004), Development of Algorithms for Accurate Wire Fault Location Using Spread Spectrum Reflectometry, MS Thesis, University of Utah, 2004.
  22. Basava S (2004), Detection and Location of Cable Faults Using Reflectometry Methods, MS Thesis, Utah State University, 2004.
  23. Amarnath N (2004), Capacitance and Inductance Sensors for the Location of Faults in Wires, MS Thesis, University of Utah, 2004.
  24. Mackay N, Penstone S (1974), High-sensitivity narrow-band time-domain reflectometer, IEEE Trans. Instrumentation and Measurement, vol. 23, no. 2, pp. 155-158, June 1974.
  25. Chen C, Roemer L, Grumbach R (1978), Cable Diagnostics for power cables, IEEE Annual Conference of Electrical Eng. Problems in Rubber and Plastic Industries, pp. 20-22, Apr. 1978.
  26. Campbell Scientific, TDR100 Instruction Manual. [<ftp://ftp.campbellsci.com/pub/outgoing/manuals/tdr100.pdf>]
  27. [Arcade Electronics](http://www.arcade-electronics.com/psiber/psiber_ct50_cabletool.html), Psiber CT50 CableTool Multifunction Cable Meter, [http://www.arcade-electronics.com/psiber/psiber\\_ct50\\_cabletool.html](http://www.arcade-electronics.com/psiber/psiber_ct50_cabletool.html)
  28. Mahoney A, Lo C, Chung Y, Furse C, Use of Genetic Algorithms and Reflectometry for Identification of Network Topologies, personal communication.
  29. Furse C, Kamdar N (2002), An inexpensive distance measuring system for navigation of robotic vehicle, Microwave and Optical Tech. Letters, vol. 33, no. 2, pp. 84-97, April 2002
  30. Oppenheim V (1975), Digital signal processing, Prentice-Hall, Englewood Cliffs, N.J., 1975
  31. Chung Y (2003), Non-Destructive Fault Location on Aging Aircraft Wiring Networks Part 1 – Cost-Optimized Solutions, IEEE AP-S and USNC/URSI National Radio Science Digest, Columbus Ohio, 2003
  32. Eclipse Co. SWR meter, <http://www.eclipse.org/Home.htm>
  33. Medelius P, Simson H (1999), Non-intrusive impedance-based cable tester, US Patent 5977773, Nov. 1999.
  34. Smith P (2003), Spread spectrum time domain reflectometry, Ph.D. dissertation, Utah State University, 2003.
  35. Furse C, Smith P, Safavi M, Lo C (2005), Feasibility of Spread Spectrum Reflectometry for Location of Arcs on Live Wires, IEEE Journal of Sensors, Vol.5, No.



6, Dec 2005, pp.1445-1450

36. Smith P, Furse C, Gunther J (2005), Fault Location on Aircraft Wiring Using Spread Spectrum Time Domain Reflectometry, IEEE Sensors Journal, Vol.5, No. 6, Dec. 2005, pp. 1469-1478
37. Furse C, Lo C, Chung Y, Smith P, Pendayala P, Nagoti K (2005), Spread Spectrum Sensors for Critical Fault Location on Live Wire Networks, Journal of Structural Control and Health Monitoring, Vol 12, 2005, pp. 257-267
38. Lo C, Furse C, Noise Domain Reflectometry for Wire Fault Location, IEEE Trans. EMC, Vol. 47, No. 1, Feb. 2005, pp.97-104
39. Furse C, Chung Y, Lo C, Pendayala P (2006), A Critical Comparison of Reflectometry Methods for Location of Wiring Faults, Smart Structures and Systems, Vol. 2, No.1, 2006, pp. 25-46
40. Griffiths L, Parakh R, Furse C, Baker B (2006), The Invisible Fray: A Critical Analysis of the Use of Reflectometry for Fray Location, IEEE Journal of Sensors, Volume 6, Issue 3, June 2006 pp. 697 – 670
41. M.Haugen, LiveWire Test Labs (<http://livewiretest.com>) , Personal communication, 1-31-11.