

## NEW DEVELOPMENTS IN MIXING, FLOCCULATION AND FLOTATION FOR INDUSTRIAL WASTEWATER PRETREATMENT AND MUNICIPAL WASTEWATER TREATMENT

Miroslav Colic\*<sup>1</sup>, Dwain Morse<sup>1</sup>, Wade Morse<sup>1</sup>, Jan D. Miller<sup>2</sup>

<sup>1</sup>Clean Water Technology Inc.

6860 Cortona Dr., Building A

Goleta, CA 93117

Email: [mcolic@cleanwatertech.com](mailto:mcolic@cleanwatertech.com); Fax: (805)-685-9105

<sup>2</sup>University of Utah, Salt Lake City

### ABSTRACT

Solid/liquid separations are commonly the first step in any wastewater treatment. Such technologies are mature and new developments are rare. However, in the last decade some significant improvements in separation techniques for industrial wastewater pretreatment have been implemented. Advances in the technology include more efficient, faster centrifugal mixing of treatment chemicals and wastewater contaminants, "in situ" continuous flow coagulation and flocculation, implementation of very high molecular weight flocculants and development of more efficient flotation technologies. Recent developments and improvements of commonly used dissolved air flotation units along with development and application of centrifugal flotation units, cavitation air flotation and suspended air flotation will be discussed. Case studies are also described. Hybrid centrifugal – dissolved air flotation technologies provide the best of both systems: efficient continuous flow mixing and in line flocculation with the nucleation and entrainment of fine dissolved air bubbles. This development has resulted in systems with very efficient removal of particulate contaminants, a small footprint, drier sludge, durable long lasting flocs, fast response and treatment of the total wastewater stream (no recycling characteristic for DAFs). The design of on-line turbidity driven sensors for automatic control of coagulant and flocculant dosage is also underway. Computational fluid dynamics (CFD) has been used to design better flotation tanks with a vortical flow pattern that results in the formation of a dense air bed inside the tank. Such fine bubble layers prevent sedimentation of already floated heavier particulates, which results in significantly higher flotation rates.

### KEYWORDS

Industrial wastewater pretreatment, mixing, flocculation, flotation, sludge thickening

### INTRODUCTION

Sedimentation is one of the favorite gravity-separation methods to remove contaminants in water treatment. Most oils have low density and cannot be separated by sedimentation from water streams. Thus, flotation is a much more suitable technique to remove oil and particles with low density from water during or after de-emulsification. Flotation is a

process in which one or more specific particulate constituents of a slurry or suspension of finely dispersed particles or droplets become attached to gas bubbles so that they can be separated from water and/or other constituents. Gas/particle aggregates float to the top of the flotation vessel where they are separated from water and other non - floatable constituents.

Flotation processes in water and wastewater treatment are designed to remove all suspended particles, colloids, emulsions, and even some ions or soluble organics that can be precipitated or adsorbed on suspended solids. In this case, the process is optimized by the maximum recovery of cleaned water with the lowest concentration of contaminants. It is also often desired that the recovered sludge contain a high percentage of solids. Such solids can sometimes be recycled and reused. The design features and operating conditions of flotation equipment used for this purpose must be modified accordingly. It is evident that the processes causing water loss to the froth phase or migration of solids to the water phase must be minimized and appropriate conditions established for complete particle recovery. A recent review summarizes new developments in flotation as a wastewater treatment technique (Rubio et al., 2002).

It is particularly common to encounter wastewater that contains a mixture of suspended particles and stable oil emulsions. It is difficult to remove oily contaminants from wastewater and other natural and industrial systems containing oil. Oil can be present as a nondispersed surface layer, usually floating at the air/water interface. Such layers can easily be removed. On the other hand, if oil is present as a dispersed phase in the form of fine droplets (oil in water emulsions), separation is much more difficult. Many emulsions are stabilized with surfactants or other emulsifying agents. Modern emulsions often contain droplets, which are very small (size range of less than 10 microns) and stabilized with powerful emulsifying agents. De-emulsification and oil extraction from such systems present particular challenges. Moreover, such processes have to be economically feasible to be accepted by industry.

One of the key steps in the flotation method is the introduction of air bubbles into water. In early flotation machines, coarse bubbles (2 to 5 mm) were introduced into the contaminated water by blowing air through canvas or other porous material. In some impeller-based machines, air could be introduced from the atmosphere without compressors or blowers. This type of flotation, in which impeller action is used to provide bubbles, is known as induced-air flotation (IAF) and also produces fairly coarse bubbles. Such flotation methods are not suitable for wastewater treatment and oil extraction. Jameson (Clayton et al., 1991) developed an improved version of induced-air flotation, which was more successful in the removal of fats, oil, and grease from the wastewater. Another flotation method, called dissolved-air flotation (DAF), is much more common in the treatment of oily wastewater (Bratby and Marais, 1977; Kiuri, 2001). In DAF, a stream of wastewater is saturated with air at elevated pressures up to 5 atm (40-70 psig). Bubbles are formed by a reduction in pressure as the pre-saturated water is forced to flow through needle valves or specific orifices. Small bubbles are formed, and continuously flowing particles are brought into contact with bubbles. There is a price to pay for having such small bubbles (up to 20 microns): Such bubbles rise very slowly to

the surface of the tank. This is the main driver of the large dimensions for DAF tanks. Final solubility of gas in water, even at high pressures, also results in fairly low air-to-water ratios. Air-to-water ratios of 0.15:1 by volume are common in DAF systems, and it is very difficult to achieve higher ratios. Therefore, classical DAF systems are not efficient in treating wastewater with more than 1% of suspended solids.

In this manuscript we will discuss some recent developments in DAF and non-DAF techniques along with improvements in mixing, flocculation, flotation, tank design and sludge collection. Such developments enabled the application of flotation in pretreatment of high strength industrial wastewater. Improvements in applications of flotation in municipal sludge thickening will also be discussed.

## **DAF SYSTEMS IN WASTEWATER TREATMENT**

### **Overview of DAF Systems**

DAF units come in many geometries (rectangular, cylindrical etc.). However, the systems most commonly produced today are rectangular-shaped units using recycle pressurization to provide dissolved air for bubble nucleation and flotation (Ross et al., 2000). As illustrated in Figure 1, a typical DAF system consists of the following primary components:

1. Contact cell or "bloom chamber." In this chamber, the mixing of dissolved air with flocculated particles in the influent wastewater occurs. Upon pressure release, bubbles nucleate and attach themselves to particles. The contact cell also provides even distribution of flow across the width of the unit.
2. Flotation tank. The flotation tank provides time and surface area for the flotation (rise of bubbles and attached particles).
3. Surface skimmer. The skimmer provides the means for removal of float (sludge) from the flotation cell for transfer to dewatering and disposal and/or reuse. The most commonly used system involves a series of flights pulled by a chain drive system with variable –speed, timer –operated drives.
4. Bottom skimmer. The bottom skimmer likewise provides for the removal of any sedimented particles from the bottom of the tank.
5. Effluent discharge baffle and chamber. This component provides for physical separation of clarified water from flocculated particles and bottoms prior to discharge from the units through weirs or similar structures.
6. Air saturation and bubble nucleation (whitewater) system. Provides the required amount of air in the proper form (bubble sizes in the range between 20 and 100 microns), ideally using minimum recycle flow. The whitewater system uses pump pressurization to force air into solution with a clarified recycle effluent stream. The air-water solution is

then injected into the incoming wastewater stream to encourage bubble-solid contact and flotation.

**Figure 1 - Schematic Presentation of the DAF System (adapted from Infilco-Degremont web site)**

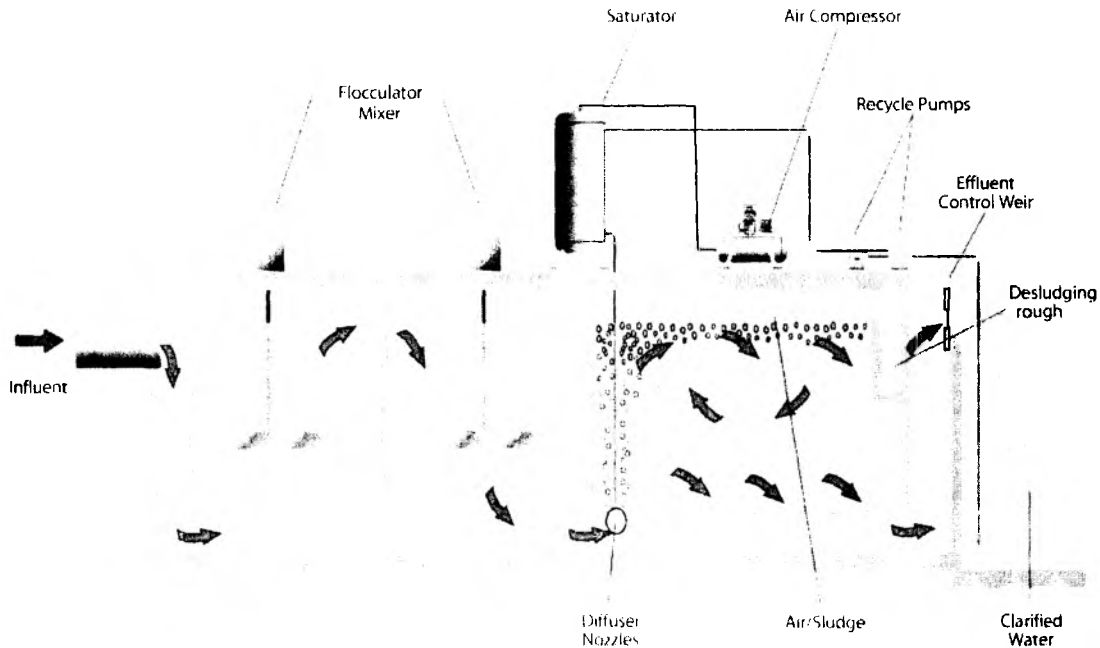

Flotation systems need several other supporting components for their optimal operation (Ross et al., 2000).

1. Screening. Proper screening of large solids (e.g. product solids, trash, soil) from an industrial wastewater stream reduces the solids loading, chemical consumption downstream and maintenance requirements due to clogged valves, orifices, pumps and piping. Screening is one of the most often overlooked parts of the total system. Savings by cutting the screen from the system design can later result in a significant increase in the cost of treatment.
2. Equalization Tanks (EQ). Proper equalization of an industrial effluent can provide a more constant and homogeneous flow to the flotation unit. This can improve the effectiveness of the chemical treatment program used for coagulation and flocculation prior to flotation. In addition equalization reduces hydraulic surging, which can be detrimental to the system performance. In some cases EQ tanks can be sized to allow operation of the flotation units during specific time periods (e.g., a single plant shift), thus reducing operator labor costs.
3. Chemical addition. Most chemical addition systems utilize either flocculation (floc) tubes or flash/floc tanks to introduce chemicals into process flow. Recently

designed hybrid centrifugal – dissolved air systems add coagulants or flocculants directly into the flotation chamber – bubble nucleation unit. The coagulants and flocculants must be prediluted with water in chemical mixing tanks with proper mixdown systems. Enough time must be allowed to hydrate – activate polymers after dilution with water or to dissolve granular flocculants. The coagulation and flocculation systems must be designed to provide a proper amount of mixing energy and time for the adequate mixing of chemicals with wastewater constituents but without break-up of formed flocs. Prior to coagulation and flocculation precise pH control can significantly improve system performance and help save on dosage of coagulants and flocculants. The pH can be adjusted in EQ tanks, with fine tuning inside floc tubes or flash mixing tanks or inside the centrifugal chamber of centrifugal flotation units.

4. Floc/sludge handling. Modern flotation technologies can produce sludge with solids loadings over 10%. Collecting, transferring and pumping such sludge is a challenge. Proper selection of transfer pumps, storage/draining tanks and dewatering systems can significantly lower the total cost of wastewater treatment. Polymers that are nontoxic are available. This enables reuse of sludge in some situations such as animal feeding operations.

5. Sensors and automatic control systems. Most users prefer systems that are virtually fully automated. This is only possible with application of high quality sensors that monitor system performance and adjust variables as needed. For instance systems that monitor the pH and adjust it by controlling acid or base dosing pumps are quite reliable. It is still difficult to find reliable systems for adjusting dosage of coagulants and flocculants, as wastewater changes with time.

**Figure 2 - Schematic Presentation of the Total Flotation System (Adapted from Ross et al., 2000)**

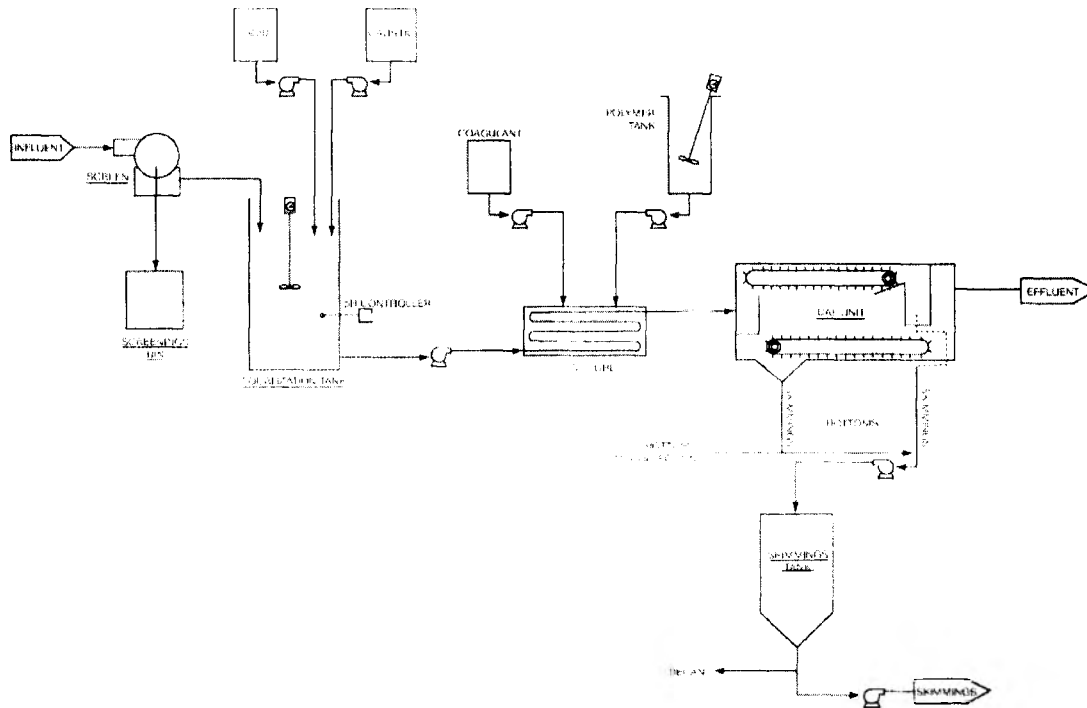

### Advances in DAF Design for Industrial Wastewater Pretreatment

Advances in DAF design include improved air saturation systems, recycle pressurization, flotation tank design, skimming and sludge handling design. Improvements in air saturation design have had perhaps the most dramatic effect on the design and specifications of DAF systems over the past two decades (Ross et al., 2000). Over the years most DAF manufacturers have made a transition from full-flow pressurization to recycle-flow pressurization for the creation of whitewater to induce flotation. Pressurizing the total wastewater influent to the flotation cell was possible only at low pressures below 50 psi, which limited the amount of air going into solution and number of nucleated bubbles. Coagulation and flocculation upstream of full-flow pressurization system exposes the flocs to high shear forces and turbulence inside the pressurization pumps, pressurization tanks and pressure control valve/orifice prior to entering the flotation cell (Ross et al., 2000). This tends to destroy flocs, thereby producing carry-over (particles in clarified effluent), thereby limiting the effectiveness of the system. Recycle pressurization involves pressurization of a sidestream of clarified effluent for return to the flotation cell. Systems with recycle pressurization can operate at higher pressures and minimize the destruction of flocs formed in the flocculation units. Recently, hybrid centrifugal – dissolved air systems have been described, which overcome this problem and pressurize full-flow inside a centrifugal flotation chamber

during simultaneous floc nucleation and bubble formation (Morse et al., 2004a 2004b, Rosa and Rubio, 2005).

We will first discuss improvements in air saturation and bubble nucleation (whitewater) systems for DAF systems that occurred during the last few decades (Ross et al., 2000, 2003, Bratby et al., 2004, Kiuri, 2001). Most early DAF systems used centrifugal process pumps to force wastewater flow into a pressurization tank at a design pressure of less than 50 psi. Air compressors were used to produce compressed air at pressures 10-20 psi greater than the recycle pressure. Compressed air was then injected into the recycle stream somewhere between the pump discharge and the pressurization tanks. The combined pressure and retention time in the tank forced the air into solution. Water surface elevation under the layer of air was regulated. Typical saturator tanks include some of the following features (Bratby et al., 2004): packing within a tank to encourage turbulence and better mixing of incoming water with the pool of water inside the pressurization tanks, a mixer to provide turbulence and additional air/liquid contact, poor outlet configurations that allow large bubbles to escape, and variable speed pressurization pumps intended to allow operator adjustments of the air/solids ratio. All of the above features had some serious flaws, as described in detail in Bratby et al., (2004). For instance, packing within a tank allowed the formation of biomass, which plugged the tank.

While investigating problems with the classical DAF saturation systems, Bratby et al., (2004) made following conclusions: dissolution of gas in water is a simple and straightforward process, depending on the pressure, temperature, the solubility of gas in question in water and the surface area of the liquid available for gas transfer; the solubility of nitrogen in water is roughly half the solubility of oxygen, thus for air (78% nitrogen and only 21% oxygen), accumulation of nitrogen in the space above the water level in the pressurization tank rapidly lowers the efficiency of the water saturation with gas to 2/3 of the initial degree of saturation. Continuous venting to remove nitrogen from the headspace atmosphere is essential for process optimization and maintenance of process efficiency. Modifications of the water entering/exiting the pressurization tank systems are needed to avoid unstable hydraulics that could lead to vortex formation and rogue bubble formation in the pressurized flow discharged to the flotation tank, where such large bubbles can disrupt stability of the sludge on top of the tank, and result in carry-over of fine particles in the effluent. The details of the optimized saturation tank design are described in Bratby et al. (2004). In short, recycle wastewater from the pressurization pump enters the tank through a nozzle, sized for an exit velocity in the range of 12 to 18 m/s to provide sufficient energy to disperse the pressurized flow stream. Water droplets hit the top impingement baffle, which further enhances mixing of water and air. Water then falls to the bottom of the tank where it hits the bottom baffle, which prevents vortex formation and rogue rough bubble formation (“burping”). Nitrogen concentration in the headspace over the liquid is controlled via the continuous purging system, with timed bursts to vent off excess accumulated gas. Such modified whitewater systems work with air saturation efficiency close to 97%, as opposed to 65% or lower with the classical DAF air saturation systems.

Another notable improvement in the air saturation systems in DAF is the use of air-handling recycle pumps that can pressurize water with entrained air without causing cavitation or vapor lock (Ross et al., 2000, 2003). These air - handling pumps include regenerative turbines and special multi-phased centrifugal pumps, which can handle limited air injection (10-20% v/v). The advantages of air-handling pumps include the ability to operate at higher pressures (up to 120 psi) vs 50 psi for traditional centrifugal pumps and higher air saturation efficiency due to high shear forces of the pump impeller. High pressure and higher saturation efficiency result in better volumetric efficiency (up to 250% more dissolved air per unit volume of recycle). The mechanical energy of the pump can also produce small bubbles from undissolved air in the pressurization solution. Pressurization tanks in such systems are only used to prevent rogue bubble formation and allow for venting excess air. Therefore, pressurization tanks in such systems can be much smaller. Finally, since air - handling pumps create vacuum suction at the location where air is injected air can be drawn from external ambient air or low pressure compressors. In traditional DAFs with classical centrifugal pump design compressed air must be supplied at 10 to 20 psi greater than the pump operating pressure. The major disadvantages of air-handling pumps are greater horsepower requirements and closer tolerances needed in manufacturing regenerative turbine pumps. Wear caused by solids in the clarified effluent can reduce pump effectiveness over time.

Another significant advance in the design of the DAF and other flotation systems happened in the area of flotation tank design. Multiphase computational fluid dynamics (CFD) models have been applied to optimize tank geometry and flow of water with suspended gas and flocs inside the tank (Ta et al., 2001). The general flow pattern has been compared with flow visualization using the underwater cameras and various soluble and insoluble dyes (green, red etc.). Comparison of average fluid velocity was carried out using acoustic Doppler velocimetry ADV measurements.

Such studies identified two major possible changes in the tank design that could allow much higher flow velocities without floc breakup and appearance of resuspended solids in the clarified water effluent. The first tank modification included the addition of square baffles inside the tank. The height, location and angle of such baffles have been varied until flow with low turbulence and minimum floc breakup was identified. Details of CFD calculations, and experimental tank design have been described by Desam et al., (2001).

Another recent development in flotation tank design has been the introduction of a false bed -- a thin stiff plate with numerous large round orifices above the real bed inside the flotation tank. Such plate has low flow resistance and modifies fluid flow inside the tank. In classical flotation tanks, the layer of bubbles thins along the length of tank. However, introduction of false bed results in vertical flow of water in the flotation space above the plate and distributes it evenly throughout the horizontal cross-section of the tank. This results in continuously regenerated thick micro-bubble bed in the tank. This bubble layer filters out any sedimenting small particles. The lower surface of the micro-bubble bed is really a horizontal one. It is located somewhat above the false bed plate controlling the flow in the flotation space. The clarified water below the micro-bubble bed is totally



clear. It can be said that in such tanks filtering of particles through the micro-bubbles layer plays a crucial role in the removal of the suspended solids (Kiuri, 2001).

Improvements in sludge skimming/removal and draining will be discussed later in the context of improvements in sludge thickening applications.

## **CENTRIFUGAL FLOTATION SYSTEMS**

As mentioned earlier, DAF systems have some serious limitations. While small bubbles used in such systems yield better contaminant removal efficiencies than IAF or other flotation techniques, there is a price to pay for small bubbles: rise time of particles attached to bubbles is minutes, which results in long water residence time inside flotation tanks and a large footprint – tank size. The solubility of air in water and a necessity of recycling instead of full flow treatment limit the number of bubbles that can be produced in such systems. Until recently, these matters limited the use of DAF systems for applications in which high strength industrial wastewater was treated. Coagulation and flocculation are performed ahead of bubble nucleation. Therefore bubble attachment is the only mechanism of particle removal. If gases could nucleate inside simultaneously nucleated flocs, more efficient processes can be developed. To address these and other limitations of DAF systems other flotation techniques have been developed and applied in industrial wastewater pretreatment.

### **Air Sparged Hydrocyclone Flotation (ASH)**

One of the recent developments in flotation technology circumvented some of these problems. In particular, the air-sparged hydrocyclone (ASH) couples a porous cylindrical membrane with design features of a hydrocyclone (Miller, 1981). Gas is introduced through the porous membrane while wastewater is pumped through the hydrocyclone. Such a device is not dependent on the gas solubility and can introduce air-to-water ratios as high as 100:1. Because the bubbles are sheared off the wall of the porous membrane due to the high velocity and centrifugal forces inside the hydrocyclone, they are broken up into very small sizes comparable to those observed in the DAF. Thus, even though the ASH is essentially a mechanically sparged device similar to the IAF or early flotation devices, it does not suffer from similar problems. The ASH is one of the first centrifugal flotation techniques that was developed and applied in the treatment of wastewater. The ASH and other centrifugal flotation systems will be described below.

Because the ASH is essentially a modified hydrocyclone device, it has similar restrictions. Removed particulates in such devices are forced through an overflow device known as the vortex finder. In the ASH, the creation of an overflow results in a separate stream of contaminated water with a low concentration of solids. This deficiency results in sludge with low particulate concentrations and a larger volume of waste.

Below, we discuss modifications to the ASH device. Bubble-accelerated flotation (BAF) evolved from ASH technology to address operational limitations resulting from the traditional stream-splitting characteristics of hydrocyclones. BAF no longer incorporates

a cleaned-water underflow restriction that forces the froth and contaminants to be ejected through a vortex finder. Removing the underflow restriction in the BAF improves the consistency and ease of operation. The point at which the stream exits the BAF hydrocyclone, the bubble/particle aggregates have already formed, and coagulation and flocculation are complete before the froth particles are ejected with the cleaned water through the underflow. The requirement to separate this froth in the receiving tank from the treated water results in the new system described below.

### **Bubble Accelerated Flotation (BAF)**

#### **Description and Principles of Operation**

The BAF system consists of a bubble chamber and a BAF tank. The bubble chamber can be operated with sparged air, induced air, vacuum, electro-flotation and even dissolved air. We will describe the air-sparged bubble chamber and BAF system. Such systems are commercially installed and successfully operated in over twenty locations within the U.S. See Morse et al. (2000 and 2001), Owen et al. (1999), and Colic et al. (2001) for detailed descriptions of this system. Figure 3 contains an illustration of the air-sparged bubble chamber. Wastewater is introduced through a liquid/liquid hydrocyclone head (tangential injection) at the top of the unit. The tangential inlet creates a swirl flow and causes centrifugal acceleration as the water is forced into a swirl layer against the inner wall of an inert porous tube. A gas plenum, which encloses the porous tube, is pressurized commonly with low-pressure air from a blower. The air pressure must slightly exceed the water pressure due to the centrifugal acceleration and the resistance of the tube itself. Gas

**Figure 3 - Schematic Presentation of the Bubble Chamber (BC)**

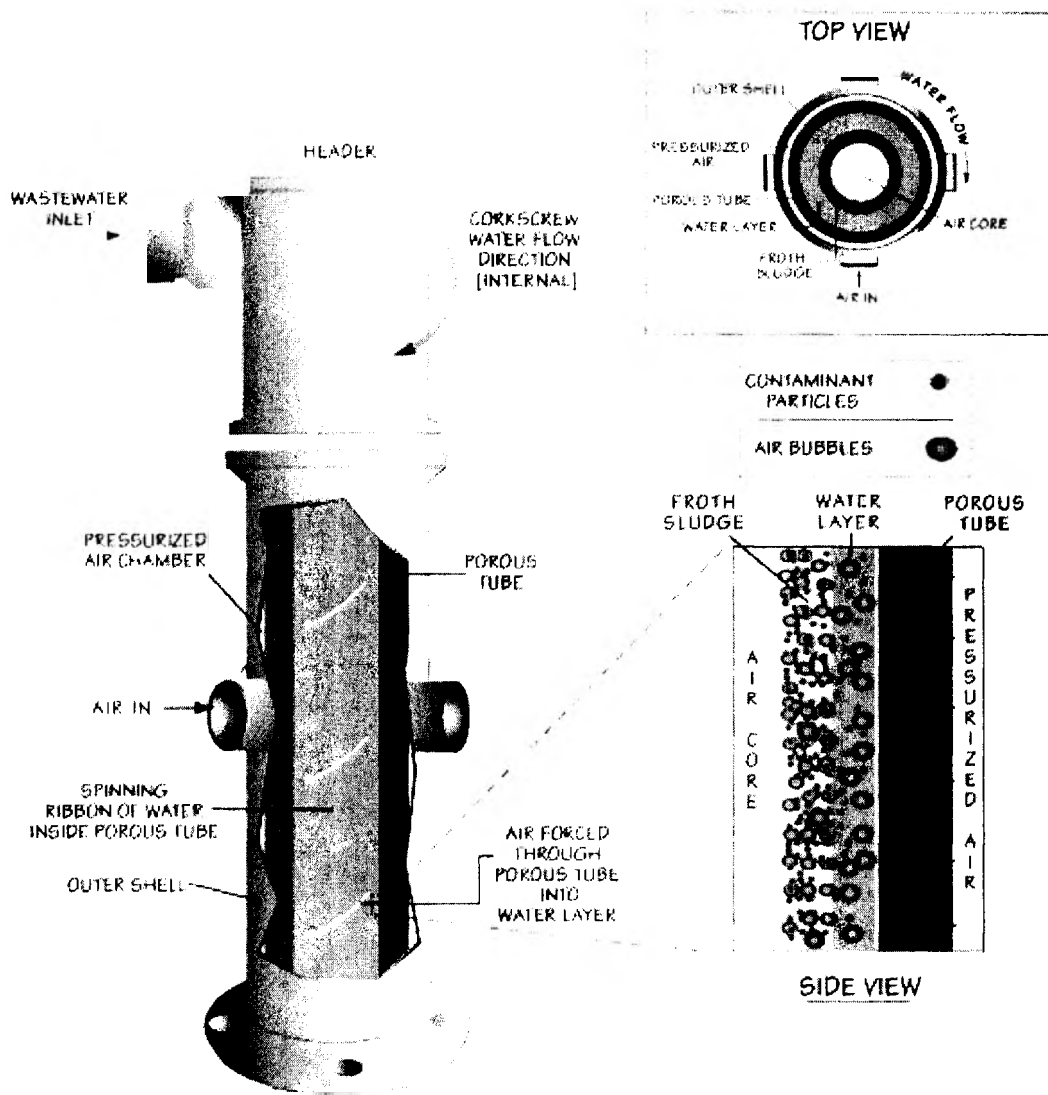

forced through the porous tube generates bubbles on the inside surface due to high shear. These bubbles are extremely buoyant in the centrifugal field because of the effective radial pressure gradient in the swirl layer generated by the hydrocyclone action. The bubbles accelerate toward the inner surface of the swirl layer. In addition to creating the radial acceleration of the bubbles, the centrifugal field also aids in the classification of particles with densities different

**Figure 4 - Schematic Presentation of the BAF System**

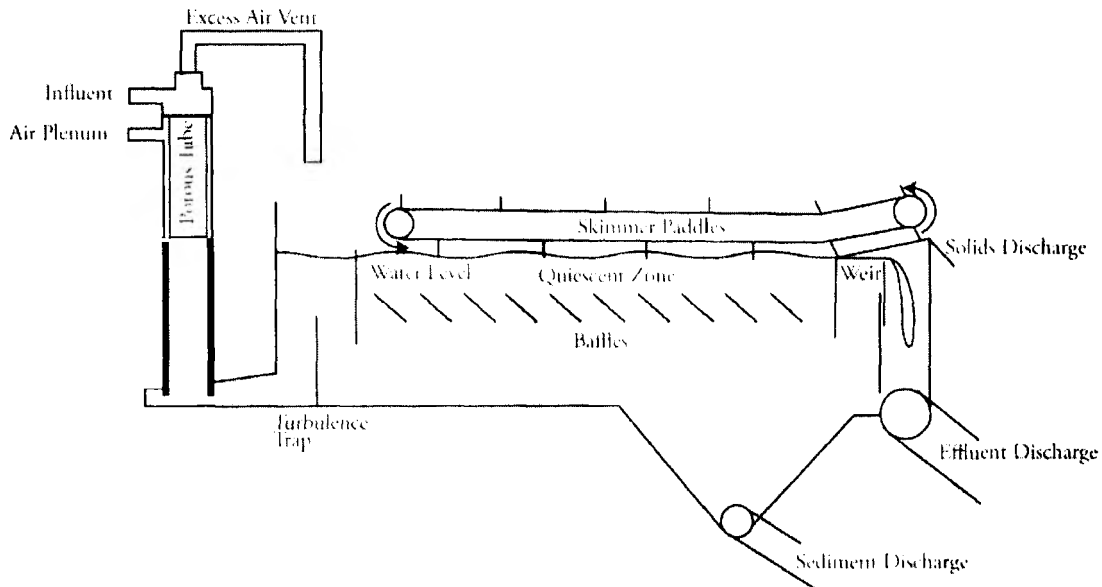

from that of water. The acceleration across the swirl layer usually ranges from 25 to 1,000 Gs during routine operation. Even though the residence time of the liquid stream in the bubble chamber is only a fraction of a second, due to their rapid acceleration, the bubbles traverse the short distance across the swirl layer (typically 1 cm for a 15-cm diameter unit) in milliseconds. During this time, the bubbles collide with particles moving toward the porous tube and form bubble/particle aggregates. Another advantage of the sparging gas is that it cleans and protects the porous tube from scaling and fouling.

Given the small bubble size, large bubble flux, and the kinetic paths of the bubbles through the swirl layer, gas transfer rates are very high. This results in the ability to remove volatile organic species or to aerate the water if desired.

The flotation process is completed outside the bubble chamber in the BAF tank. In a DAF system, the tank is designed to allow sufficient residence time for the bubbles and particles to collide and for the resulting aggregates to rise to the surface. This results in low hydraulic flow rates in order to permit bubble/particle aggregates to form and to float to the surface without being swept out of the system. In DAF systems, the low hydraulic flow rate is accomplished by increasing the cross-sectional area of the flow and consequently enlarging the tanks. Consequently, for the DAF there is a trade-off between footprint and residence time.

The design needs for BAF separation tanks are completely different. The bubble chamber has already created bubble/particle/polymer aggregates before they enter the tank. The tank is simply used as a separator and not to achieve bubble/particle contact. Unlike other flotation tanks, the effluent from the bubble chamber can enter the tank above the water level, resulting in a shorter distance for the froth to reach the surface. This feature, combined with the fact that the aggregates are already formed, permits much higher hydraulic flow rates through the flotation tank. Figure 4 illustrates the BAF tank with the bubble chamber attached.

**The Hybrid Centrifugal – Dissolved Air Flotation System: Gas Energy Mixing Management (GEM)**

Description and Principles of Operation

**Figure 5 – Schematic Presentation of the LCPP/LSGM**

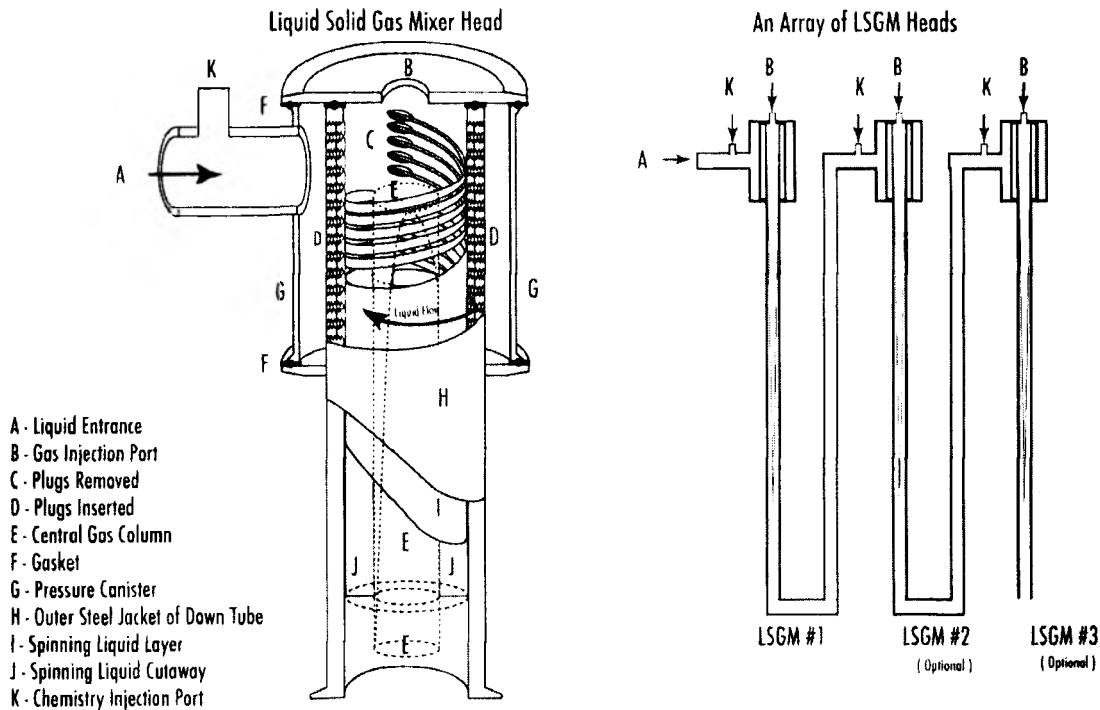

As mentioned in the introduction, in dissolved-air flotation, bubbles are formed by a reduction in pressure of water pre-saturated with air at pressures higher than atmospheric and up to 120 psi. The supersaturated water is forced through needle valves or special orifices, and clouds of bubbles 20 to 100 microns in diameter are produced. Yet, to avoid clogging of such orifices with particles, only 20% of already cleaned water is pressurized and recycled to the wastewater stream. This results in a low-energy mixing of the main wastewater stream and the bubble stream. Treatment chemicals, coagulants and

flocculants have to be added in mixing tanks upstream. As already described earlier, floc separation happens in this tank, which requires quiescent conditions and a large footprint.

We proposed that a more efficient flotation system could be developed by combining high-energy centrifugal mixing of a liquid cyclone system (we termed it the liquid cyclone particle positioner, LCPP) with dissolved air as a source of flotation bubbles. As in the case of BAF, coagulants and flocculants can be delivered *in situ* directly into the flotation unit. The bubble chamber was replaced with the LCPP for more efficient mixing of treatment chemicals, which occurs during bubble formation and nucleation. Such a procedure results in flocs, which are very porous and loaded with entrained and entrapped air.

As shown in Figure 5 the LCPP also acts as a liquid-solid-gas mixer (LSGM). Replacing the classical hydrocyclone head with the LCPP provides extremely energetic mixing by sequentially transporting liquid and entrained particles and gas bubbles throughout a centrifugally rotating liquid layer. Microturbulence in such vortices results in all particles and bubbles down to colloidal and molecular size acting as little mixers. Axial and radial forces inside the LCPP help mix coagulants and flocculants with the particles. Uncoiling of polymer and better mixing of ultrahigh-molecular-weight polymers is achieved in the LCPP. Such efficient mixing is important for proper flocculation of suspended particles.

Further modification of LCPP heads, as opposed to hydrocyclone heads, introduced multiple holes with plugs inside the LSGM heads, as shown in Figure 6. By changing the number of plugs, we can modify the mixing energy and head pressure from very low to very high. In this way, we can mix low-molecular-weight coagulant at relatively high energy and high-molecular-weight flocculants at relatively medium and low mixing energy to promote final large floc formation.

Figure 7 presents a schematic of the GEM flotation system. It should be noted that for the sake of clarity only one LSGM head is presented. If more treatment chemicals are added, the LSGM head can be used to properly mix every additional chemical at its proper mixing energy (one mixing head per addition). Water and gas are introduced into the LSGM on top and pumped through the LCPP chamber. After rapid mixing (seconds), pressure is released with the cavitation plate. Nucleating bubbles and flocs are well mixed. As mentioned before, this results in the formation of large flocs full of entrained and entrapped air. Such flocs are already separated from water inside the LCPP nucleation chamber. As flocs enter the tank, they rise quickly to the top where they are skimmed and sent to solids dewatering devices.

As compared to the ASH and BAF, the GEM system uses less energy, since there is no need for air blowers for air sparging. This also results in less noise. Controlled mixing energy produces stable flocs with much less carryover and higher solids loading. The footprint for this system is still only 10 to 20% of the classical DAF or clarifier devices. A blanket of small bubbles inside the tank acts as a "gas filter," filtering out clean water while preventing the transport of small pinpoint flocs into the clean water stream. Also, when wastewater with surfactants is treated, for some reason no foaming occurs inside

the GEM system. Finally, it is possible to install sensors close to the nucleation chamber and observe any disturbance in flocculation performance almost instantaneously. This can be used to install turbidity-driven, chemical-additive dosage-control systems. Such

**Figure 6 – Schematic Presentation of the LSGM Heads**

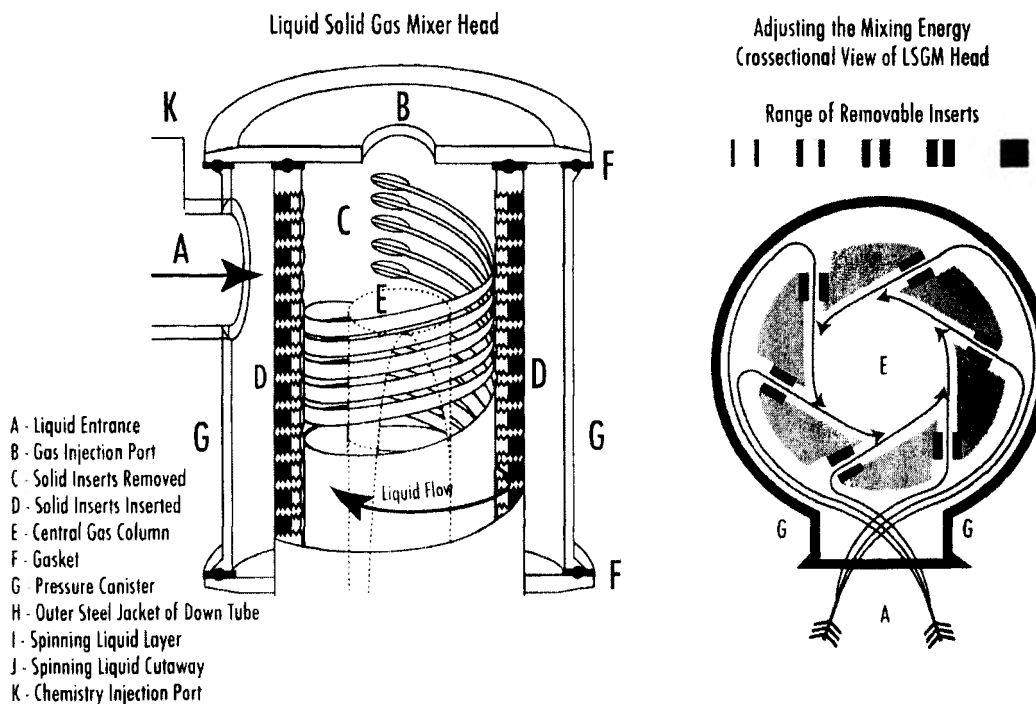

systems can save significant amounts of money and produce a better quality of outgoing wastewater effluent. A detailed description of the GEM system can be found in Morse et al. (2004a, 2004b).

### OTHER CENTRIFUGAL FLOTATION SYSTEMS

Swirl flow of fluids and mixing with coagulants, flocculants, and air bubbles occurs inside the air-sparged hydrocyclone (ASH) and other derived centrifugal flotation systems (CFS). Several versions of inverted ASH with upward water flow have been reported. Hydrocyclone flotation systems with induced or dissolved air have also been tested. All these techniques incorporate a vortex finder similar to the classical ASH with

**Figure 7 – Schematic Presentation of the Hybrid Centrifugal – Dissolved Air Flotation System**

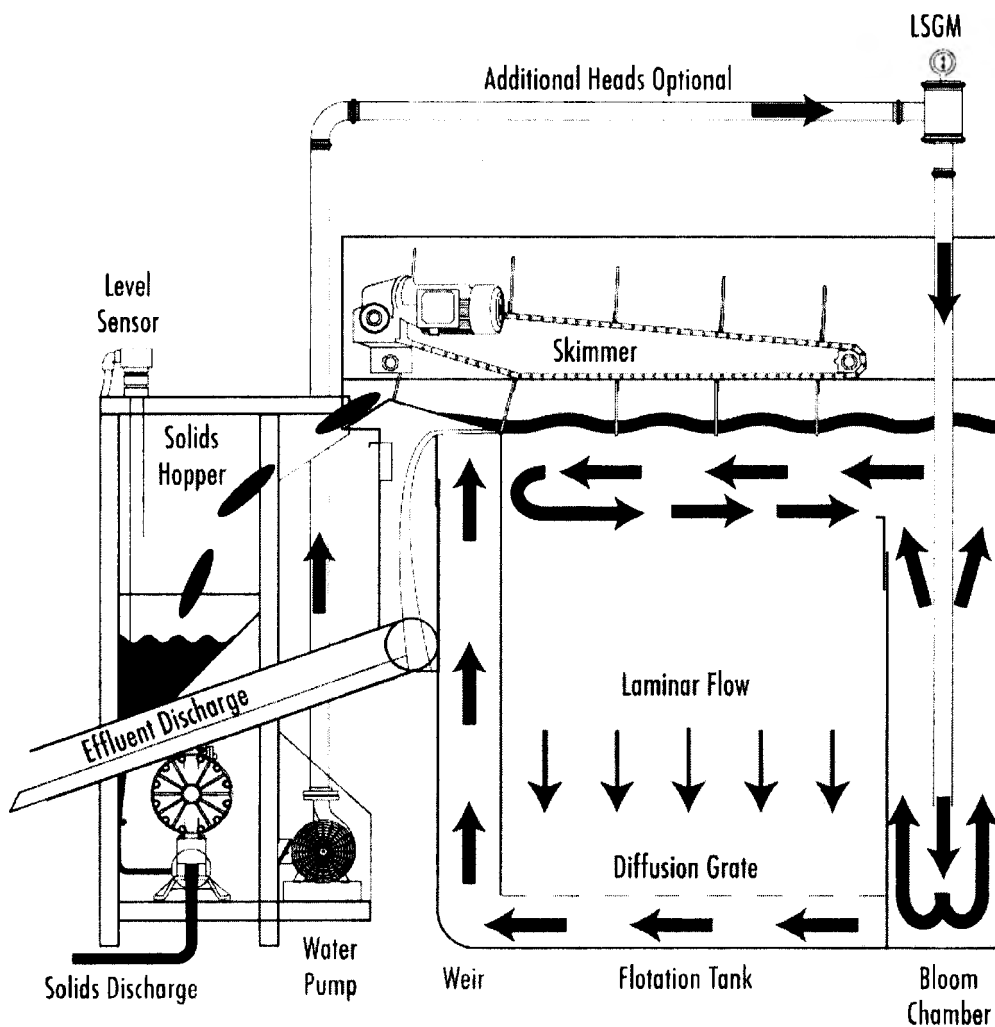

the attendant problems discussed earlier. The advantage of such techniques is that they do not use large separation tanks. This results in a smaller footprint and reduced cost of equipment compared to BAF, DAF, and induced-air flotation.



Modified versions of the jet (Jameson cell) flotation system have also been developed and applied. In a recent advancement of the Jameson cell technology, a new “low shear” method is used to mix the air, untreated wastewater, and flocculants. As in the previously described induced-air BAF system, untreated wastewater and flocculants are gently introduced into the top of the cylinder used for centrifugal mixing (termed the downcomer for Jameson cell systems). A portion of the clean effluent is recycled back into the top of the downcomer. The recycle effluent passes through an orifice, accelerating the liquid to produce a simple liquid jet. The kinetic energy of the jet results in air being entrained into the downcomer in much the same way as air might be entrained into a bucket of water using a hose. Air is dragged down into the liquid and broken up into small bubbles by the turbulence in the top of the downcomer. The Jameson cell thereby utilizes the energy of the fluid to induce air into the cell, rather than requiring an external compressor or blower. As in the case of the BAF system, the presence of air bubbles at the time of flocculation is extremely beneficial, as it results in the bubbles being entrapped with the actual floc structure. The incorporation of bubbles in the floc structure provides buoyancy and allows particles to be floated independent of their surface characteristics. The downward velocity of the bubble/liquid mixture in the downcomer is designed such that all bubbles have to descend and emerge into a reservoir (or cell) at the bottom of the downcomer. The reservoir acts as a disengagement zone, allowing the aerated floc structures to float to the surface to form a sludge layer. As in the case of BAF and GEM, separation already happens inside the centrifugal force column (in this case downcomer). The sludge overflows the reservoir into a launder, whilst the cleaned effluent passes to the next stage in the process.

Other modifications of jet flotation include the DAF jet (dissolved-air mode) and addition of one more cylinder around the downcomer to lead separated flocs towards the top of the separation tank (Feris et al., 2004). While these modifications increase the cost and result in a more complicated system they also increase the separation efficiency.

Another turbulent *in situ* centrifugal flotation system, termed flocculation flotation (FF), was recently developed (daRosa and Rubio, 2005). As in the case of GEM, BAF, and the modified jet-flotation cell, polymer and air are added at the same time inside a centrifugal mixing system. Dissolved air is used for smaller bubbles. As in the case of BAF and the GEM system, large flocs entrained with air develop when high-molecular-weight flocculants are used. Multiple cylinders around the downcomer are used, similar to the modified jet-flotation cell. The air excess leaves through the centrifugal cylinders at the top, and the flocs float very fast within seconds after leaving the downcomer cylinder. A novel flocculation and helical mixing system has also been developed by the same group (Carissimi and Rubio, 2005).

## **OTHER FLOTATION TECHNIQUES**

While it is impossible within the given space to review all recent developments in flotation techniques we will mention few other popular systems.

Cavitation air flotation (CAF) utilizes an aerator (rotating disc), which draws ambient air down a shaft and injects "micro-bubbles" directly into the wastewater (as reported in Rubio et al., 2002). However, there is no knowledge of any fundamental work with this flotation technique. CAF is not as efficient as DAF or centrifugal flotation systems, but is very economically feasible and simple to operate.

Gas aphanes and suspended air flotation (SAF) is based on the use of colloidal gas aphanes, micro-foams or simply micro-gas – suspended air dispersions (as reported in Rubio et al., 2002). They are dispersions of air in liquids formed with the use of a venturi generator, which introduces a gas to a circulating surfactant solution in a region of high velocity and low pressure. This produces very small stable bubbles, which range in size from 10 to 50 microns and provide a large amount of surface area. The disadvantage of this technique is that it adds surfactants into wastewater.

Nozzle flotation (NF) process uses a gas aspiration nozzle (an eductor or exhauster) to draw air into recycled water, which in turn is discharged into a flotation vessel (similar to the dispersed-air conventional IAF machines) to develop a two-phase mixture of air and water (as described in Rubio et al., 2002). Low initial cost, energy use and maintenance are characteristics of this system. Applications reported have been exclusively in the treatment of oily wastewater from petrochemical industries.

## **CASE STUDIES: APPLICATIONS OF SOME NOVEL FLOTATION TECHNIQUES**

### **BAF Applications (example of centrifugal flotation system)**

Examples of installations and performance data for the air-sparged BAF are outlined in Table 1. There are currently more than twenty systems installed within the continental U.S. The advantages of the system are small footprint, high performance, high solids loading in the sludge, and low amount of treatment chemicals used. The technology is particularly efficient in the removal of free and emulsified fats, oils, and grease (FOG). Following successful flocculation, the BAF system can also be used to remove low-density submicron particles such as latex particles used in screen-printing of fabrics. The BAF system has also been used to remove totally hydrophilic particles such as zeolites or quartz. The BAF system has a much shorter response time to changes in chemistry (seconds as opposed to hours in clarifiers or DAF). This is very useful in wastewater treatment, as the composition of incoming water often changes, and adjustments must be made quickly.

Numerous approaches were used to coagulate and flocculate particulates in wastewater prior to the BAF treatment. The pH of the suspension is usually adjusted close to the pH of the isoelectric point to reduce consumption of coagulants (charge neutralizing agents). The residual charge is then partially neutralized with either inorganic coagulants or low-molecular-weight cationic polymers (polyamines, polyDADMACs etc.). Dual-polymer flocculation with high-molecular-weight (HMW) cationic and anionic polyacrylamide flocculants (PAMs) is then performed. Dual-polymer flocculation with HMW PAMs

yield large, stable flocs, which float very efficiently inside the BAF tank. We also observed that if the main portion of the charge is neutralized with low-molecular-weight cationic coagulants, the BAF performance is not as good. Among the most efficient polymeric flocculants used were Cytec's C-498 HMW cationic polyacrylamide with ultrahigh-molecular-weight (>5,000,000 D) and 0.55 charge density and Cytec's anionic polyacrylamide A-130 HMW with-molecular-weight estimated to be over 7,000,000 D. When animal feed applications of the collected sludge are desired, Cytec's "GRAS"

**Table 1- Examples of full-scale operating installations of BAF flotation systems.**

**BAF™ Performance Classified by Industry**

<b>Meat &amp; Seafood Processors</b>										
Location	Process	BOD Before (mg/l)	BOD After (mg/l)	BOD % Removal	TSS Before (mg/l)	TSS After (mg/l)	TSS % Removal	FOG Before (mg/l)	FOG After (mg/l)	FOG % Removal
Los Angeles, CA	Seafood	3190	1308	59	1675	67	96	n/a	n/a	n/a
Westport, WA	Seafood	1375	564	59	484	189	61	166	25	85
Salinas, CA	Renderer	1000	300	70	800	80	90	300	30	90
Denver, CO	Renderer	n/a	n/a	n/a	600	60	90	560	28	95
Klingerston, PA	Egg Product	656	210	68	391	133	66	n/a	n/a	n/a
West Liberty, IA	Turkey	600	210	65	532	133	75	n/a	n/a	n/a
Kent, WA	Meat	1882	320	83	1120	56	95	1100	22	98

<b>Food Processors</b>										
Location	Process	BOD Before (mg/l)	BOD After (mg/l)	BOD % Removal	TSS Before (mg/l)	TSS After (mg/l)	TSS % Removal	FOG Before (mg/l)	FOG After (mg/l)	FOG % Removal
Los Angeles, CA	Mayonnaise & Salad Dressing	11925	954	92	7500	75	99	n/a	n/a	n/a
Tennessee	Salad Dressing & Vegetables	12083	2900	76	3000	150	95	n/a	n/a	n/a
Madera, CA	Olive Processor	2200	1100	50	1000	50	95	316	95	70
Modesto, CA	Corn & Potato	335	672	77	250	50	98	n/a	n/a	n/a
Denver, CO	Corn & Potato	2958	710	76	1960	98	95	n/a	n/a	n/a
Umatilla, OR	Onions	1099	747	32	540	54	90	n/a	n/a	n/a
Hilmar, CA	Dairy	2900	1450	50	1500	75	95	266	80	70

### Laundry & Wash Facilities

Location	Process	BOD Before (mg/l)	BOD After (mg/l)	BOD % Removal	TSS Before (mg/l)	TSS After (mg/l)	TSS % Removal	FOG Before (mg/l)	FOG After (mg/l)	FOG % Removal
Los Angeles, CA	Pre-Wash & Dye	489	318	35	416	50	88	n/a	n/a	n/a
Fresno, CA	Wash-Rack	n/a	n/a	n/a	n/a	n/a	n/a	400	20	95
Lexington, KY	Laundry	347	250	28	450	45	90	n/a	n/a	n/a

(generally regarded as safe) polymers, such as 234 GDH cationic moderate-molecular-weight polyacrylamide, are used. When necessary, emulsion polymers were also used with the BAF system. Dual-polymer flocculation also results in very low residual polymer concentration in the effluent. This is particularly important, when flotation is used as a pretreatment ahead of membrane separation processes. Membranes are particularly sensitive to fouling with cationic polymers.

It was also observed that high-molecular-weight polymeric flocculants can be added directly into the bubble chamber head. Large batch mixing tanks or floc tubes can therefore be avoided. Powerful vortex mixing and wall effects inside the bubble chamber tube result in better uncoiling of polymers with minimum polymer and floc breakage. HMW flocculants can therefore achieve superb flocculation inside the bubble chamber. This often results in the formation of large flocs with diameters of up to 10 cm. The flocs are very stable, with high solids loading of between 10 and 30% upon short drainage. The best flocs are usually produced when using a combination of HMW cationic and anionic flocculants. Fan et al. (2000) show that dual-polymer flocculation actually results in more efficient uncoiling of the HMW polymeric flocculants. The uncoiled flocculant chains then act as better bridging agents. Vortex mixing inside the centrifugal field within the bubble chamber seems to enhance this process. Additional research should be performed to investigate these processes.

### Applications of GEM System in Wastewater Treatment (example of hybrid centrifugal –dissolved air flotation system)

As mentioned previously, the GEM system is particularly efficient in the treatment of wastewater with high solids loading (higher than 10 000 ppm of TSS). The GEM system was tested in the treatment of such oily wastewater from fish processing plants, rendering plants, snack-food processing plants, and salad-dressing processing plants. Water with up to 70,000 ppm of TSS and 150,000 of CODs was treated, and the TSS was reduced below 100 ppm, the CODs below 15,000 ppm, and complete removal of the FOGs was achieved. The GEM system is currently being tested as a polishing tertiary treatment before membrane separation. In such applications, where very low concentrations of TSS

and FOGs are present (less than 10 ppm), the system shows great promise. Further, the GEM system was successful in removing TSS and FOG from fish-processing plants that use sea water with very high conductivity (up to 50,000 micromhos/cm). Appropriate proprietary chemistry had to be used to flocculate particles and FOGs at such high ionic strength, under which conditions polymeric flocculants are difficult to uncoil. Positively charged coagulants such as aluminum sulfate were used to overcharge negatively charged solids. Then ultrahigh-molecular-weight, medium charge anionic emulsion flocculants, such as A-4816 from Cytec Corporation (molecular weight 40,000,000 D, 30% charge), were added to achieve bridging flocculation. LCPP mixing might have helped in the polymeric flocculant uncoiling process. Further research will test such a hypothesis. Performance of the GEM system is documented in Table 2.

**Table 2 - Examples of pilot plant and full - scale operating installations of GEM flotation systems**

<b>Wastewater</b>	<b>TSS before</b>	<b>TSS after</b>	<b>COD before</b>	<b>COD after</b>
Seafood processor	3,500 ppm	120 ppm	27,000 ppm	10,000 ppm
Seafood processor	28,000 ppm	150 ppm	62,000 ppm	12,000 ppm
Rendering plant	25,000 ppm	80 ppm	67,000 ppm	13,000 ppm
Food processing	1,500 ppm	35 ppm	12,000 ppm	3,000 ppm
Municipal	285 ppm	50 ppm	320 ppm	180 ppm
Juice processing	385 ppm	10 ppm	9,000 ppm	5,500 ppm
Salad dressing	120,000 ppm	50 ppm	150,000 ppm	12,000 ppm
Jeans washing	30 ppm	3 ppm	100 ppm	60 ppm
Laundry	5,500 ppm	5 ppm	24,000 ppm	3,500 ppm
Snack food plant	45,000 ppm	55 ppm	130,000 ppm	10,000 ppm

Note: seafood processing and rendering wastewater had very high salt concentration (conductivity 50,000 micromhos/cm)

The performance of the modified DAF with air handling pump is described in Ross et al., (2003). The performance of the cavitation air flotation systems can be found at the company website ([www.hydrocal.com](http://www.hydrocal.com)). In spite of many advantages, the high-throughput, high-efficiency dissolved air and centrifugal flotation systems have their problems. Air-handling pumps as well as modified centrifugal pumps for such flotation systems use more energy when compared to classical DAFs. Closer tolerances of such pumps or heads of LSGM in the GEM system require good screening to remove large particles such as sand that can cause wear and reduce pump lifetime. To achieve the above-described high removal efficiency of contaminants and sludge with high solids loading, high-molecular-weight polymeric flocculants have to be used. However, the ability to clarify wastewater with high efficiency and handle waste streams with ultrahigh solids loading makes such systems very attractive for the treatment of industrial wastewater streams or as a pretreatment ahead of membrane separation or bioreactor systems. Future studies will show just how cost-effective they can be in municipal sludge-thickening applications.

## **NEW DEVELOPMENTS IN FLOTATION TECHNOLOGY FOR SLUDGE THICKENING**

Thickening sludges by dissolved air flotation is well established and has been around for many years. Recent improvements in air saturation described above significantly extended the range of application of DAF systems so that sludge with initial concentration above 10,000 mg/l of suspended solids can now be thickened with flotation systems.

Another important parameter, when evaluating the success of flotation as thickening technology is the solids loading of the final float. The principal mechanism effecting sludge thickening during flotation is drainage of flotation layer above the water level. As expected, solids concentration is highest near the top of the float in contact with air and decreases as the float layers approach the water level.

It is apparent that the float skimming system should disturb the float as little as possible. Good flotation systems have skimmers with adjustable speed and time on and off. Moreover, only the topmost layer of the sludge that is already drained should be skimmed. This requires sludge level sensors that can control the distance between the bottom of the sludge layer and the bottom of the sludge scraper. By ensuring that the bottom of the scraper blades are at least 2 inches or more above the water level, the dilution effects may be minimized. Bratby et al., (2004) described in some detail how to accomplish these goals and optimize the design of DAF's for sludge thickening. Such DAF systems can achieve sludge solids loading up to 7%, when used to thicken municipal combined primary and secondary sludge.

Another way to improve solids loading in sludge produced by flotation thickening is to improve the sludge float pumping system. After removal of the float from the flotation tank solids are deposited in sludge hopper and then pumped for further processing. Flat sludge sumps with pumps controlled by the sludge level resulted in solids separation from adsorbed water. While such drainage resulted in more concentrated sludge, several problems followed: sludge floated on top of the liquid, more concentrated sludge is difficult to pump, and it does not flow easily on flat or gently sloping surfaces, unless they are quite smooth. The top solids dry out and produce cake, which is very difficult to pump or remove.

To remedy these problems flotation designers developed float troughs and collection systems, which are coated with fusion bonded epoxy if metal, or PVC if concrete, and shaped to encourage the float to move efficiently to the collection box outlet leading to the pump intake (Bratby et al., 2004). The pump intake connection has been positioned in a confined sump located well below the nominal floor of the sump. The purpose of this feature is to concentrate the floating solids in small surface area right over the pump inlet. The pump is then controlled to shut down not on level, but rather when the pump breaks suction, guaranteeing that the floating material has reached the pump inlet.

Improvements in air saturation, flotation tank design, sludge skimming and removing and automation resulted in flotation thickening systems that are quite competitive to centrifuges and clarifier – thickeners. The flotation thickeners offer following advantages (Bratby et al., 2004): Allowing double the solids loading rate per surface area when co-thickening primary and secondary sludge, having no problem in thickening scum from either the primary or secondary scum collection systems, allowing scum and sludge to be transported to the thickening process with maximum water flow, allowing the separation and capture of grit from a continuous bottom sludge removal system when co-thickening primary and secondary sludge, continuously producing a homogeneously mixed thickened sludge product that is of ideal quality for feeding digesters, allowing all solids processing recycling loads to be concentrated into one stream and achieving a significant BOD and TSS reduction in the liquid effluent. Preliminary results with centrifugal flotation systems show that they can even further improve the performance of sludge thickening, yielding float with solids loading over 10%.

## **SUMMARY AND CONCLUSIONS**

Wastewater treatment depends on many interdependent factors. These factors should be carefully considered when selecting and designing integrated water-treatment systems. Flotation devices are an excellent choice for treatment of water contaminated with fats, oils, and grease, as well as particles with low density and particulates with tendencies to float rather than sediment, such as algae or biological sludge.

Total flow of wastewater to be treated per day, and peak flows at different times of day are to be taken into account when selecting a flotation system. For large flows and low contaminant loads at municipal wastewater treatment plants, classical dissolved-air flotation devices are still the best choice. DAFs can be scaled up to flows of more than 20

$\text{m}^3/\text{min}$ . Centrifugal flotation devices perform well at low and medium flows (20 l/min to  $3 \text{ m}^3/\text{min}$ ). Such systems are particularly efficient for treatment of industrial wastewater with high loads of suspended solids (TSS more than 5000 mg/l) and high loads of FOGs (more than 500 mg/l). Centrifugal systems have so far not been tested for sludge-thickening applications. Centrifugal flotation systems (CFS) have been quite successful in treatment of food-processing wastewater (snack-food preparation, dairy, rendering, chicken, beef, poultry processing, bakeries, breweries, sausages, sauces, mayonnaise, vegetable processing, fruit and juice processing, desserts, fish processing, corn food, potato food, etc.). Application of CFS in the treatment of petroleum, automotive, washracks, laundry, and textile wastewater has also been described.

Flotation system size (footprint) for a given flow of wastewater is commonly described in terms of hydraulic loading rates (HLR). In the SI system, the units of  $\text{m}^3/\text{h}$  for flow and  $\text{m}^2$  for equipment size are used; therefore, HLR units are m/h (flow divided by equipment area). The HLR values for various flotation systems are summarized in Table 3. The DAFs used in wastewater treatment usually have a low HLR, between 5 and 50 m/h. Centrifugal flotation systems can operate at HLRs that are an order of magnitude higher; therefore, such systems have a significantly lower space requirement. Additional space savings are achieved by *in situ* flocculation within the centrifugal mixing devices. As described earlier, fast mixing and flocculation in such systems occurs in seconds, as opposed to minutes in classical flocculation tanks.

The concentration of solids (solids loading) in the produced sludge is another important parameter to consider when choosing the appropriate equipment/strategy for solid/liquid separations in wastewater treatment. DAFs produce sludge with solids loading between 1 and 6%. Centrifugal flotation systems produce sludge with up to 20% solids. Ironically, this may produce a problem, since such sludge is very viscous and dries fast. Adequate pumps and sludge disposal equipment should be available; otherwise, sludge has to be diluted for further processing. More research is needed in how to efficiently remove concentrated sludge without disturbing the bottom layer and causing the transport of particulates into the clean water product (Bratby et al., 2004). No matter how efficient flocculation may be, incomplete transport will decrease the performance of the flotation system.

Average bubble size, size distribution, bubble stability, and rise time in tanks are also important parameters for flotation systems. Average bubble sizes for some common flotation devices are summarized in Table 4. Centrifugal forces inside CFS further reduce the average bubble size. Detailed measurements of average bubble size in the ASH system compared to bubbles produced with air sparging only, showed bubbles with almost an order of magnitude smaller diameter. Jet flotation also produces bubbles with average sizes that are 2 to 4 times smaller than those produced in other induced-air flotation (IAF) systems. As explained previously, centrifugal forces in the CFS induce solid/liquid separation inside the chamber before water even enters the separation tank. Therefore, rise time for solids and bubbles inside tanks is much shorter, comparable to noncentrifugal flotation systems.



**Table 3 - Average hydraulic loading rates (m/h) for some flotation devices used in wastewater treatment systems. Abbreviations used: IAF: induced-air flotation, DAF: dissolved air flotation, ASH: air sparged hydrocyclone flotation, BAF: bubble accelerated flotation, GEM: gas energy management flotation, FF: flocculation-flotation**

Flotation technique/system	Hydraulic loading rate (m/h)
IAF	30-500
DAF	5-50
Jet flotation	50-350
ASH	100-800
BAF	20-400
GEM	20-350
FF	140-2000

Centrifugal flotation systems offer an alternative to traditional dissolved-air flotation with several advantages. The centrifugal flotation systems float contaminants more effectively than DAF, because all wastewater is treated in the centrifugal contactor. Centrifugal forces provide for very efficient mixing of contaminants, bubbles, and treatment chemicals. The hybrid dissolved-air centrifugal flotation systems such as GEM are particularly effective. The efficient mixing action inside the LCPP head means that very high-molecular-weight polymeric flocculants can be used for treatment. The tanks included in GEM systems are considerably smaller in volume and footprint than DAF tanks. This leads to savings in material costs and land usage. The fast response time of the GEM system (seconds) is also convenient for rapidly changing industrial wastewater influent treatment (on-line chemistry dosage sensors). GEM systems have been installed and operated in a number of situations, of which only a few are mentioned here as examples. The GEM system performs exceptionally well for removal of FOG from industrial wastewater. However, removal of colloidal particles, including hydrophilic materials such as quartz, is also very efficient. Removal rates of over 99% of total suspended solids (TSS), 80% of chemical oxygen demand (COD), and 95% of FOG (over 99.5% of suspended emulsified FOG) are not uncommon. Soluble contaminants such as heavy metals or organics can also be removed if precipitated or adsorbed. The system operates best when used with the dual-polymeric flocculants to aggregate suspended particulates. *In situ* ultrafast coagulation and flocculation occur within the LCPP, with no need for additional tanks. Modular mixing energy application inside the LCPP can mix low-molecular-weight coagulants at relatively high energy and high-

molecular-weight flocculants at relatively medium or low mixing energies. The GEM system can be used to treat wastewater with up to 100,000 ppm of TSS, which is much higher than that treated by DAF. Other centrifugal flotation systems such as flocculation-flotation (FF) or modified Jameson-jet flotation offer similar advantages. In spite of their many advantages, the above-described high-throughput, high-efficiency flotation systems have their problems. Air-handling pumps as well as modified centrifugal pumps use more energy when compared to classical DAFs. Closer tolerances of such pumps or heads of LSGM in the GEM system require good screening to remove large particles such as sand that can cause wear and reduce pump lifetime. To achieve the high removal efficiency of contaminants and sludge with high solids loading, more expensive high-molecular-weight polymeric flocculants have to be used in systems such as GEM or FF. Development of coagulant and flocculant dosage systems that respond to changes in wastewater properties is also needed to fully automate such systems without loss of efficiency.

**Table 4 - Average bubble size reported for some flotation systems used in wastewater treatment. Abbreviations used: IAF: induced-air flotation, DAF: dissolved air flotation, ASH: air sparged hydrocyclone flotation, GEM: gas energy management flotation, FF: flocculation-flotation, EF: electroflotation, CAF: cavitation air flotation**

<b>Flotation technique/system</b>	<b>Average bubble size, <math>\mu\text{m}</math></b>
IAF	1000
DAF	20-50
Jet Flotation	300-600
ASH	80-200
GEM	15-40
FF	100
EF	15
CAF	30-200

**ACKNOWLEDGEMENTS:** We wish to thank Jason Hicks, Thomas Matherly and other members of the CWT team for their help in the preparation of this manuscript. We also thank members of Miller's group from the University of Utah for their assistance in the preparations of this manuscript.

## REFERENCES

- Bratby, J.; Marais, G.V.R., (1977) Flotation. In Purchas D.B. (Ed.), *Solid/Liquid Separation Equipment Scale –Up*. Upland Press, pp. 155-168.
- Bratby, J; Ambrose W. (1995) Design and Control of Flotation Thickeners. *Water Sci. Technol.*, **31**, 24-261.
- Bratby, J.; Jones G.; Uhte, W. (2004) State-of –Practice of DAFT Technology – Is there Still a Place for it? *77<sup>th</sup> Annual Conference of the Water Environ Federation, WEFTEC, New Orleans, L CD-ROM Conference Proceedings*.
- Carissimi, E.; Rubio, J. (2005) The Floccs Generator Reactor-FGR: A New Basis for Flocculation and Solid-liquid separation. *Int. J. Miner. Process.*, **75**, 237-247.
- Clayton, R.; Jameson, G.J.; Manlapig, E.V. (1991) The Development and Application of Jameson Cell. *Mineral Engineering*, **4**, 925-933.
- Colic, M.; Morse, D.E.; Morse, W.O.; Matherly, T.G.; Carty, S.; Miller J.D. (2001) From Air-sparged Hydrocyclone to Bubble Accelerated Flotation: Mineral Industry Technology sets Stage for Development of New Wastewater Treatment Flotation. *Proceedings Engineering Foundation Conference, Froth Flotation/Dissolved Air Flotation: Bridging the Gap*, UEF Conferences, Tahoe City, California, in press.
- Da Rosa, J.; Rubio, J. (2005) The FF (flocculation-flotation) Process, in *Minerals Engineering* (web version available at [www.elsevier.com/locate/mineng](http://www.elsevier.com/locate/mineng)), in press.
- Desam, P.R.; Datta, A.; Morse, W.; Miller, J.D. (2001) A Computational Fluid Dynamics (CFD) Model for a Bubble Separation Tank Used in Wastewater Treatment, *Proceedings Engineering Foundation Conference, Froth Flotation/Dissolved Air Flotation: Bridging the Gap*, UEF Conferences, Tahoe City, California, in press.
- Fan, A.X.; Turro, N.J.; Somasundaran, P.; (2000) A Study of Dual Polymer Flocculation. *Colloids Surf. A*, **162**, 141-148.
- Feris, L.A.; De Leon, A.T.; Santander M.; Rubio, J. (2004) Advances in The Adsorptive Particulate Flotation Process, *Int. J. Miner. Process.*, **74**, 101-106.
- Jameson, G.J. (1999) Hydrophobicity and Flocc Density in Induced-air Flotation for Water Treatment. *Colloids Surf. A*, **151**, 269-281.
- Kiuri, H.J. (2001) Development of Dissolved Air Flotation Technology from the 1<sup>st</sup> Generation to the Newest 3<sup>rd</sup> one (very thick microbubbles) with High Flow-rates (DAF in turbulent flow conditions). *Water Science and Technology*, **8**, 1-8.
- Miller, J. D. (1981) Air-sparged Hydrocyclone and Method. *US Pat. 4,279,743*.
- Morse, D.E.; DeWitt, J.B.; Gnegy, B.; Hendrickson, E.D.; Jovine, R.; Matlick, A.; Matherly, T.G.; Morse, W.O.; Owen, J.J.; (2000) Fluid Conditioning System and Method. *US Pat. 6,106,711*.
- Morse, D.E.; Hendrickson E.D.; Jovine, R.; Morse, W.O.; Mandoza D.W.; (2001) Fluid Conditioning System. *US Pat. 6,171,488*.

- Morse, D.E.; Morse, W.O.; Matherly T.G.; Hendrickson E.D. (2001) System and method to improve flotation systems. *US Patent Application 20010032812*.
- Morse, D.E.; Morse W.O; Matherly, T.G (2004a) System and method of gas energy management for particle flotation and separation. *US Patent Application 20040178152*.
- Morse, D.E.; Morse, W.O.; Matherly, T.G. (2004b) Adjustable Contaminated Liquid Mixing Apparatus. *US Patent Application 20040178153*.
- Owen, J.J.; Morse, D.E.; Morse, W.O.; Jovine, R. (1999) New Developments in Flotation Equipment for Water Treatment Systems, in *Advances in Flotation Technology*, B.K. Parekh and J.D. Miller, eds., SME, Littleton, Colorado, pp. 381-389.
- Ross, C.C.; Smith, B.M.; Valentine, G.E. (2000) Rethinking Dissolved Air Flotation (DAF) Design for Industrial Pretreatment. *2000 Water Environment Federation and Purdue University Industrial Wastes Technical Conference, St. Louis, Missouri*, CD-ROM Conference Proceedings.
- Ross, C.C.; Valentine, G.E.; Smith, B.M.; Pierce, J.P. (2003) Recent Advances and Applications of Dissolved Air Flotation for Industrial Pretreatment. *2003 Industrial Water/Wastewater Program, North Carolina AWWA/WEA Annual Conference, Greensboro, North Carolina*.
- Rubio, J; Souza, M.L., Smith, R.W. (2002) Overview of Flotation as a Wastewater Treatment Technique. *Minerals Eng.*, **15**, 139-155.
- Ta, C.T.; Beckley, J.; Eades, A. (2001) A Multiphase CFD Model of DAF Process. *Water Sci. Technol.* **43**, 153-157.