

## Soot volume fraction from Extinction in JP-8 and Heptane pool fires

Tara L. Henriksen<sup>1</sup>, Gus Nathan<sup>2</sup>, Zeyad Alwahabi<sup>3</sup>, Jennifer Spinti<sup>1</sup>, Eric Eddings<sup>1</sup>, Phillip J. Smith<sup>1</sup>

<sup>1</sup> Department of Chemical Engineering, University of Utah, Salt Lake City, UT 84112  
thenriks@eng.utah.edu

<sup>2</sup> School of Mechanical Engineering, University of Adelaide, S.A. 5005 Australia

<sup>3</sup> School of Chemical Engineering, University of Adelaide, S.A. 5005 Australia

### ABSTRACT

Total extinction measurements from a multiple beam experiment using a 10mW laser diode are presented and compared to calculate soot volume fraction in heavily sooting pool fires from a 150 mm diameter pan of Jet Propulsion fuel 8 (JP-8) and heptane. Trends in attenuation are critiqued for the two fuels, and estimates of the axi-symmetrical distribution of soot are established.

### 1. INTRODUCTION

The motivation for our study of soot volume fraction originated from a desire to learn more about the evolution of soot in buoyancy-driven, heavily sooting flames. Highly resolved temporal and spatial data is available for small turbulent flames that are lightly sooting [1-3, 4]. Also available are time-averaged data at a few spatial locations in large scale, heavily sooting pool fires (5-80m) as summarized by Koseki [8]. However, there is a lack of temporally and spatially resolved data available for small, well-characterized, heavily sooting pool fires.

The preferred technique for measuring soot volume fraction has been LII. LII can provide local, instantaneous volume fraction data, but it is a relative technique that must be calibrated. It also suffers from effects of signal trapping in heavily sooting conditions. The calibration is generally performed against line of sight extinction [7], which can provide a good estimate of the mean volume fraction. This study presents results from multiple beam extinction measurements performed on 15-cm diameter turbulent pool fires of JP-8 and heptane and addresses the complications associated with extracting information from these measurements. The use of multiple beams allows both the mean and instantaneous degree of axisymmetry to be measured. A sufficiently high degree of instantaneous axi-symmetry may allow improved corrections for signal trapping.

### 2. EXPERIMENTAL METHODS

#### 2.1 Pool Fire Pan Design

The pool fire pan was built at the University of Utah (see Figure 1). The circular aluminum pan has a 165.1 mm OD, with a height of 76.2 mm. Cooling water ran through a 12.7 mm shell surrounding the fire cavity. The spill pan has an equivalent depth, with a 304.6 mm ID. Fuel entered through a 6.33 mm opening in the bottom of the pan and passed through a fuel disperser to distribute the incoming fuel more uniformly. Thermocouples were installed at radial distances of 25.4 mm and 50.8 mm, corresponding to heights of 12.7 mm and 25.4 mm. The pan was securely mounted to a two-dimensional traverse. A constant fuel level in the pan was maintained by keeping the fire pan level with a reservoir pan, whose fuel height was maintained by an ultrasonic level sensor. A pump triggered with a PID control program, replenished fuel to the reservoir pan.

Water to the fire pan shell was kept at a constant flow rate of 128 mL/min, corresponding to an average exiting water temperature of 76°C as measured by a thermocouple in the exiting water stream. The level of fuel in the pan was maintained at 31.75 mm +/- 5 mm. Fluctuation in the fuel height were dramatically reflected in the temperatures measured by the two thermocouples mounted in the pan.

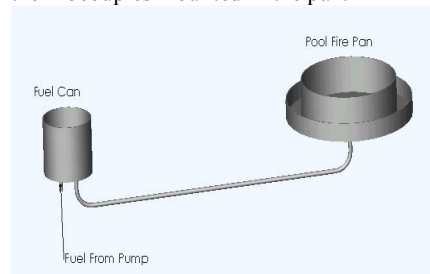

Figure 1. Pool fire pan design

#### 2.2 Multiple Beam Extinction Set-up

Extinction measurements were conducted at the University of Adelaide in a room with dimensions of 9.44m x 6.4m x 4.5m. A continuous wave 532nm laser diode, operating at 10mW with a beam diameter of 0.5mm (unfocused) passed through a series of three 50/50 beam splitters (Figure 2). The beams were oriented at angles of 0°, 45°, 90° to each other, and aligned to cross on the axis of the flame. A fourth beam provided a reference to correct for possible variations in the temporal laser power intensity. Filters and apertures were placed in front of each of the four photodetectors to minimize radiative interference. The ratio of the average value of the incident beam to the average value of each attenuated beam yielded the average attenuation, and hence, the average soot volume fraction in the flame.

The biggest source of error in determining the mean soot volume fractions in this way is the definition of the optical path length through the flame, which fluctuates in turbulent flames. This problem is reduced by using LII, which is calibrated under laminar conditions. However, the extinction performed in this way provides a useful cross-check, and also allows assessment of the axi-symmetry.

The extinction measurements were performed at five heights in the flame. The pool fire pan was attached to a traverse and was lit only once for a set of measurements though the entire flame. Measurements traversed from the bottom to the top of the flame, with a spacing of 101.6 mm. The distance from the pan base to the hood was approximately 1016 mm, with a suction rate of 0.69m<sup>3</sup>/s. Attenuation measurements were performed after steady state had been best approximated. This occurred when the feed rate to the pool fire and the temperatures of cooling water and the unburned fuel stabilized.

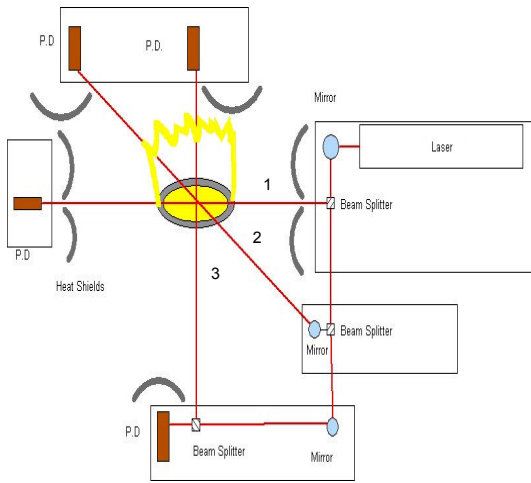

Figure 2: Multiple beam experiment

### 3. RESULTS AND DISCUSSION

#### 3.1 Soot Volume Fraction

Since LII measurements have also been performed to allow instantaneous, local soot volume fraction to be obtained, here we consider only the mean volume fraction averaged across the entire flame. This is sufficient to provide a cross-check with the LII measurements, and also provides information of instantaneous axi-symmetry that is complementary. For such measurements, the choice of attenuated path length significantly affects the results. (It is possible to use the Abel transform from a radial traverse to estimate the average radial component [5], but this is redundant given the LII measurements).

Soot volume fraction from extinction can be calculated by the following equation, used by Kent and Bastin [5]:

$$\phi = \frac{-\lambda}{6\pi \text{Im}\{(m^2 - 1)/(m^2 + 2)\}} K_{ext} \quad (1)$$

$K_{ext}$  = extinction coefficient  
 $m$  = refractive index of soot  
 $\lambda$  = wavelength of laser

Laser path length assignment warrants discussion, as its value is integral in the determination of the extinction coefficient in equation 2, where  $I_0$  and  $I$  are the incident and transmitted intensities, and  $L$  is the path length through the soot:

$$K_{ext} = \frac{\ln(I_0/I)}{L} \quad (2)$$

The dependence of  $K$  on  $\ln(I_0/I)$  means that errors get large at small values of extinction. This error was not significant for the present heavily sooting flames since  $I_0/I$  always exceeded 1.4.

We considered two approaches for resolving the issue of laser path length assignment. First we assume a mean path value and used that value to calculate the volume fraction at every height in the flame. We chose a mean length of 0.1524m, which corresponds to the diameter of our pan and is the most accurate representation of path length at the first measurement height. Second we took long exposure pictures of the flame, to capture the average path length at each corresponding height. For this calculation, we used a value for the visible amount of flame captured on film to determine the path length at each measurement height. While this approach is reasonable for flames from which no soot is emitted, it breaks down when significant quantities of soot escape from the flame.

We believe this second method most accurately represents the actual attenuated path length of the laser beam in the lower half of the flame. However it will under-estimate the length in the upper half of the flame from which significant quantities of unburned soot are evident outside the flame envelope. Figures 3 & 4 show a comparison of these two methods.

Instantaneous attenuation measurements were recorded at 400 Hz from all 4 laser beams, and averaged over 3400 points for each measurement height. The refractive index for soot was taken to be 1.57-.56i as described by Dalzell and Sarofim [6]. As expected, JP-8 yields a higher average soot volume fraction at every height. These values were obtained by averaging the soot volume fractions calculated at each measurement height in the flame, with path length obtained from method two.

In Figures 3 and 4, we compare attenuation trends with height in the flame for JP-8 and heptane respectively. In both cases, the measurements obtained using the visible path length begins to increase toward the top of the flame, while that obtained using the mean path length remains approximately constant toward the flame tip. Since the mean path length is fixed, the volume fraction based on it is directly proportional to the total extinction. Hence the steady values obtained from the mean path length toward the tip indicate that the total amount of soot is approximately constant with height. In contrast, the diameter of the visible flame decreases toward the flame tip. Hence the rise toward the flame tip in volume fraction based on the visible envelope implies that the amount of soot that is outside the visible envelope increases with flame height. That is, the mean visible path length increasingly under-estimates the true path length. This divergence occurs closer to the tip for heptane because heptane is a less heavily sooting fuel than JP8. The ratio of the two methods toward the flame tip is related to the amount of soot outside the flame envelope.

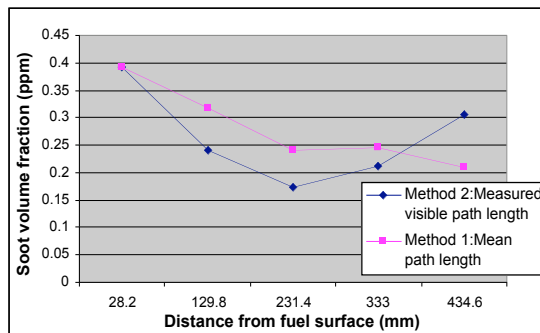

Figure 3. Path length methods 1 & 2 for JP8

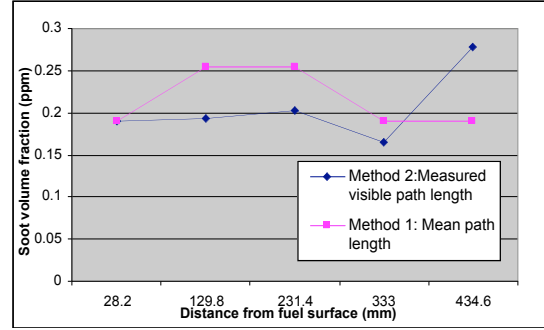

Figure 4. Path length methods 1 & 2 for heptane

### 3.2 Determination of the Degree of Axi-Symmetry

To maximise spatial resolution from LII measurements, it is desirable to image only half of the flame. To allow this data set to be used to assess the entire flame, it is necessary to demonstrate statistical axi-symmetry. In addition, the higher degree of instantaneous axi-symmetry, the more the effects of signal trapping can be accounted for.

An assessment of the degree of instantaneous axi-symmetry can be obtained by performing a correlation of the instantaneous extinction data. This is done by comparing the rise and fall of each signal with time, and then developing the corresponding correlation coefficients ( $r$ ) between the three detectors. This value of ( $r$ ) is represented by the following formula:

$$r = \frac{\sum_{i=1}^n (x_i - \bar{x})(y_i - \bar{y})}{\sqrt{\sum_{i=1}^n (x_i - \bar{x})^2} \sqrt{\sum_{i=1}^n (y_i - \bar{y})^2}} \quad (3)$$

$-1 \leq r \leq 1$

Based on the design of the fire pan, we would assume that the soot distribution would be roughly axi-symmetric. This condition will be required to compute soot volume fraction from LII measurements. Correlation results between each laser beam in the JP-8 and heptane pool fires are shown in Figures 7 and 8. The highest correlation was obtained between two of the detectors that were aligned at 45° from each other ( $R_{23}$ ), although there is not a clear trend of less correlation for the detectors aligned orthogonally (Figures 5 and 6). For example, for the heptane fuel, the lowest correlation was obtained between the other two detectors at 45° ( $R_{12}$ ). This slight bias in azimuthal correlations may be due to the location of the cooling water inlet relative to the beams. For both fuels the correlation drops markedly at the flame tip, while the JP-8 exhibits a slight peak at a height of 330mm (Fig. 7), and the heptane at around 200mm (Fig. 8). Importantly the correlations are sufficiently high (around 0.4) to demonstrate a significant degree of instantaneous axi-symmetry, despite the fact that the flame is turbulent.

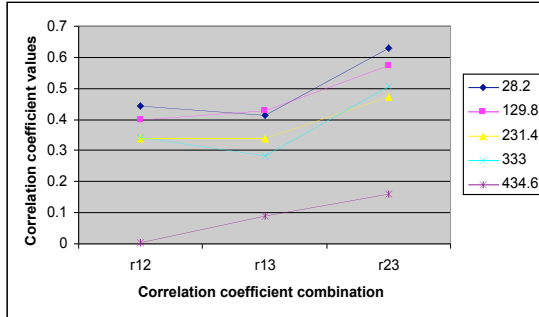

Figure 5. Correlation trends for JP8

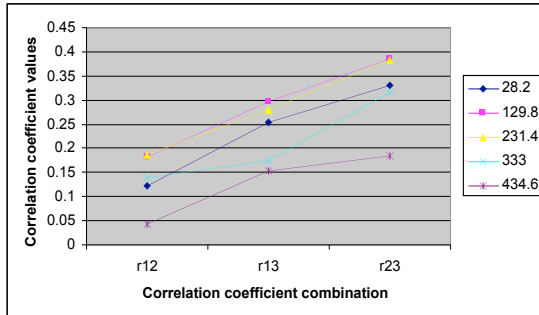

Figure 6. Correlation trends for heptane

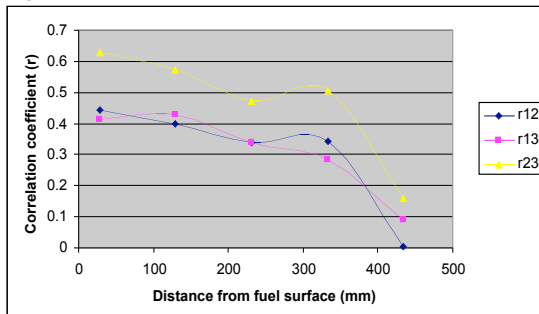

Figure 7. Correlation trends with height for JP8

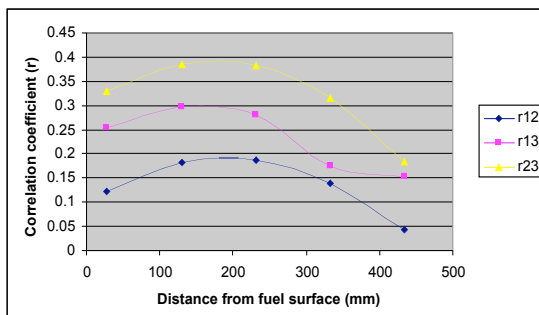

Figure 8. Correlation trends with height for heptane

#### 4. CONCLUSIONS

Results from temporally averaged soot volume fraction for 15-cm pool fires of JP-8 and heptane were presented at five measurement heights. The selection of optimum path length for the soot volume fraction calculation should be obtained by method 2 described above. In addition, by implementing the use of

multiple beam extinction, results quantifying the axis-symmetrical distribution of soot volume fraction were presented, yielding a slightly higher correlation between beams aligned 45° from each other. The fact that the instantaneous extinctions between the crossing beams exhibit a non-zero correlation implies that the flame exhibits a degree of instantaneous axis-symmetry. It suggests that a significant component of the fluctuations in extinction are large-scale, and hence probably also correlated with the large-scale puffing motions known to be present in pool fires. Of course, the correlations are less than unity, as would be expected, since the flame is turbulent, and its puffing motions are not perfectly axis-symmetric. They are also not necessarily concentric with, or aligned with, the axis of the burner. All such effects will lower the correlation between beams that cross through the axis of the burner. Nevertheless, a significant correlation between beams aligned at right angles is significant. It implies that it may be possible to partially correct for the effects of signal trapping of LII measurements based on assumed instantaneous axis-symmetry.

#### 5. ACKNOWLEDGEMENTS

This work was sponsored by the Center for the Simulation of Accidental Fires and Explosions at the University of Utah, which was funded by the U.S. Department of Energy under Contract No. LLL B341493, with matching funds provided by the University of Utah Research Fund. The authors would like to greatly acknowledge the support of Nader Qamar and Dr. Keith King at the University of Adelaide Chemical Engineering Department; Dr. Adel Sarofim, Dr. Erza Barziv, Dana Overacker, and Dr. William Ciro at the University of Utah, and the countless others who offered their advice and expertise.

#### References

1. Barlow, R. S., Sandia H2/He Flame Data - Release 2.0, <http://www.ca.sandia.gov/TNF>, Sandia National Laboratories (2003)
2. Barlow, R. S. and Carter, C. D., *Combustion and Flame* 97:261-280 (1994)
3. Barlow, R. S. and Carter, C. D., *Combustion and Flame* 104:288-299 (1996)
4. Xin, Y., and Gore, J., *35<sup>th</sup> National Heat Transfer Conference*, June 10-12 (2001)
5. Kent, J.H., Bastin, S. J., *Combustion and Flame* 56: 29-42 (1984)
6. Dalzell, W. H., and Sarofim, A. F., *Journal of Heat Transfer*, 91:100-104 (1970)
7. Kohse-Hoinghaus, K., and Jefferies, J.B., *Applied Combustion Diagnostics*, 252-286
8. Koseki, H., *Fire Safety Science: Proceedings of the Sixth International Symposium*, 6:115-132 (1999)