

USE OF SIMPLE IMMUNO-ASSAY TO DETECT ILLEGAL DRUGS
AND RECREATIONAL DRUGS OF ABUSE IN WASTEWATER

by

Alex McKendra Fisher

A thesis submitted to the faculty of
The University of Utah
in partial fulfillment of the requirements for the degree of

Master of Science

Department of Civil and Environmental Engineering

The University of Utah

May 2013

Copyright © Alex McKendra Fisher 2013

All Rights Reserved

The University of Utah Graduate School

STATEMENT OF THESIS APPROVAL

The thesis of **Alex McKendra Fisher**

has been approved by the following supervisory committee members:

Otakuye Conroy-Ben	, Chair	3/13/2012
		Date Approved
Steven Burian	, Member	3/13/2012
		Date Approved
Andy Hong	, Member	3/13/2012
		Date Approved

and by **Chris Pantelides**, Chair of
the Department of **Civil and Environmental Engineering**

and by Donna M. White, Interim Dean of The Graduate School.

ABSTRACT

Research studies indicate that drugs of abuse are prevalent in the water system and if not properly treated, could impact the environment and future societies that use reclaimed water as a drinking source. Although they are not currently regulated by the Environmental Protection Agency (EPA), it would be beneficial for wastewater treatment facilities to begin testing for drugs of abuse to determine what concentrations are present and the facilities' removal rates. This data could be used to help the facility begin to plan for additional treatment methods when the EPA implements regulation. Most treatment facilities are government based and have limited funding. A method to detect illegal drugs in the wastewater that is cost and time effective that does not require gaining permits from the Drug Enforcement Administration (DEA) will allow municipalities to begin testing and preparing for drug removal. Detection by immuno-assay is more affordable, less time consuming and does not require permits through the DEA for drug standards as do conventional detection methods.

Wastewater samples collected from Salt Lake County sewer lines and Central Valley Water Reclamation Facility were tested for caffeine, cocaine, cotinine, methamphetamine, nandrolone, oxycodone, and tetrahydrocannabinol (THC). The samples were processed and tested with Neogen Immuno-assay drug detection kits. The

drugs caffeine, cocaine, methamphetamine, oxycodone, and THC were detected at concentration ranges similar to those in other studies. The concentrations for cotinine and nandrolone were undetectable. Immuno-assays proved to effectively detect drugs of abuse in wastewater.

TABLE OF CONTENTS

ABSTRACT.....	iii
LIST OF FIGURES.....	vii
LIST OF TABLES	viii
ACKNOWLEDGMENTS	ix
Chapters	
1 INTRODUCTION.....	1
2 BACKGROUND.....	3
Importance of Drugs of Abuse in Wastewater	3
Drugs of Abuse Tested.....	4
How do Drugs Enter the Wastewater System?	11
Possible Impacts from Drugs of Abuse in Wastewater	12
Current Detection Methods	14
Current Treatment Methods	17
Use of Reclaimed Water and Drug Effects	18
3 MATERIALS AND METHODS.....	26
Sample Collection.....	26
Sample Processing.....	29
Immuno-Assay	29
4 RESULTS	36
Introduction	36
Caffeine.....	36
Cocaine.....	37
Cotinine.....	38
Methamphetamine	38
Nandrolone	39
Oxycodone	39

THC.....	40
Discussion	40
5 CONCLUSION	52
Final Remarks.....	53
APPENDIX: METHOD DEVELOPMENT DETAILS	54
REFERENCES.....	66

LIST OF FIGURES

1 - Chromatographic Process Schematic.....	23
2 - Map of Central Valley Improvement Districts	32
3 - Central Valley Water Reclamation Facility Schematic.....	33
4 - Color Variation Related to Concentration when K-Blue Substrate is Added	34
5 - Color Variation Related to Concentration after Acid is Added.....	34
6 - Immuno-Assay Reaction Process	35
7 - Caffeine Standard Curve	43
8 - Cocaine Standard Curve	44
9 - Cotinine Standard Curve	45
10 - Methamphetamine Standard Curve.....	46
11 - Nandrolone Standard Curve	47
12 - Oxycodone Standard Curve.....	48
13 - THC Standard Curve.....	49

LIST OF TABLES

1 - Drug Physical and Chemical Properties	21
2 - Concentration Ranges of Illegal Drugs Detected in Recent Publications	24
3 - Concentrations of Illegal Drugs Detected in Groundwater in Barcelona.....	25
4 - Caffeine Concentration Results	43
5 - Cocaine Concentration Results	44
6 - Methamphetamine Concentration Results.....	46
7 - Oxycodone Concentration Results.....	48
8 - THC Concentration Results.....	49
9 - Average, Maximum and Minimum Concentrations in Sewer Lines	50
10 - Mass Flux per Capita.....	50
11 - Percent Loss of Analytes due to Filtration	51
12 - Percent Removal from Wastewater Treatment.....	51

ACKNOWLEDGMENTS

I must credit a number of people, for without their support and help, this thesis may not have been completed.

First, I would like to acknowledge my parents, Keith and Stacy Fisher, who have given unconditional love and unlimited support over the years of my education. I am eternally grateful for the sacrifices they have made to make sure I achieve my personal, educational, and professional goals. My sister, Abby Fisher, has always provided emotional support and stress relief. The unlimited love and support from my grandparents, Larry and Sylvia Fisher, and Larry and Lynette Gatlin has always been motivating and inspirational. To my late grandfather, Stephen Sherrod, who taught me that I could have whatever I want in life, as long as I work hard and stay dedicated to my dreams.

Dr. Otakuye Conroy-Ben was my academic advisor for my undergraduate career and influenced me to proceed into the graduate program. Dr. Conroy-Ben offered many research topics that provided me with endless learning opportunities, ultimately leading me to this research project. Dr. Conroy provided all the necessary funding for this research and has been a great resource.

The staff at Central Valley Water Reclamation Facility was extremely helpful in sample collection. Christi Priest and Talena Walton in pretreatment contributed several

hours driving me to sewer collection sites and providing valuable information on the wastewater collection facilities.

I would like to thank all of the people who have helped me in the lab. The relationships we have built have been very valuable and special to me.

Finally, I would like to thank my boyfriend, Vince Willis, for standing by my side and not giving up on me even in the most stressful moments.

CHAPTER 1

INTRODUCTION

Pharmaceuticals and personal care products are a concern in wastewater treatment and environmental research. Endocrine disruptors and specific medications have been studied to determine how they impact the environment. Illegal and recreational drugs are of interest due to the high concentrations found in wastewater streams. The consequences from illegal drug exposure in the environment are not very well known, but it can be assumed that they will most likely have a negative impact as they will eventually be consumed by humans. Methods of detection and removal need to be implemented in wastewater treatment facilities to monitor removal rates and to reduce the concentrations being released into the environment. More precise monitoring of drugs in the wastewater will also be beneficial to forensics studies by having more accurate drug usage statistics which can be used by local law enforcement.

Current detection methods for drugs in the wastewater system are expensive and time consuming. Municipal wastewater treatment facilities are not required to test for drugs, and are not properly equipped to do so. Methods for fast and inexpensive detection could be implemented at wastewater treatment facilities to determine an approximate concentration of drugs in the wastewater and an approximate removal rate throughout the

wastewater treatment plant. Using a method that is less expensive and can be performed at the site of sample collection would benefit the wastewater treatment plant operators and inspectors by supplying rapid and accurate results.

Although the current detection methods are efficient and well known, obtaining permission to possess and test for drugs of abuse is difficult, as they are listed under Class II Controlled Substances with the Drug Enforcement Agency (DEA). Class II Controlled Substances are strictly regulated due to the potential for abuse leading to psychological or physical dependence.¹ Permits are granted by registering with the DEA, under a state license, and the registration holder is required to abide by the state and federal rule pertaining to the controlled substance. Registration must be renewed every three years, and the cost varies depending upon the controlled substance. Strict storage regulations are enforced, and personnel with access to controlled substances are required to go through thorough training. Registration can be a time consuming and expensive process.¹ As an alternative to gaining permits, the samples could be sent to a local laboratory that holds the proper permits for testing controlled substances, but this is costly and time consuming.

This report discusses some important issues of drugs of abuse in wastewater, how they are currently detected, and how they are removed from wastewater using conventional wastewater treatment methods. Tests were performed using immuno-assays to determine if this method could be used to detect concentrations of specific drugs in wastewater in a timely and inexpensive manner.

CHAPTER 2

BACKGROUND

Importance of Drugs of Abuse in Wastewater

The effects of drugs on people are fairly well known due to studies conducted on human safety. The effects of illegal drugs have been tested and evaluated to understand the dangerous effects on humans. Nicotine, which requires users to be at least 18 years of age, and oxycodone, which requires a prescription, are examples of legal drugs that are regulated to prevent abuse by users. However, little research has been done on the effects of drugs found in wastewater and the surrounding environment. Some studies have been performed on certain species, but these studies are very limited and do not represent the concentrations or the continuous exposure rates currently found in the environment. Some of the effects of drugs on humans may be relatively similar to the effects on the environmental species. These assumptions are considered throughout this report.

A study in Europe that tested 19 drugs of abuse in wastewater systems proved that wastewater analysis would also be beneficial to forensic sciences. Most drug usage statistics are reported from surveys, which are highly dependent on consumers. Concentrations found in wastewater lead to more accurate data for drug usage in specific areas.²

Drugs of Abuse Tested

The drugs used for this research are caffeine, cocaine, cotinine, methamphetamine, nandrolone, oxycodone, and tetrahydrocannabinol (THC). The chemical composition, properties, and effects of these drugs are discussed below. Table 1 displays the chemical properties of each drug.

Caffeine

Caffeine is a stimulant found naturally in beverages, like coffee and tea, and can be used as a pharmacological agent. Caffeine is one of the most commonly used drugs, consumed by 90% of the adult population, and is found in food, drinks, and supplements. An average of 120 mg/day of caffeine is consumed through beverages by Americans.³ A maximum of 12 $\mu\text{g} / \text{mL}$ of caffeine can be excreted in urine with standard caffeine consumption.⁴ Concentrations up to 73 $\mu\text{g} / \text{L}$ of caffeine have been found in wastewater in Europe.⁵ As the population continues to consume more caffeine, and it becomes more prominent in wastewater streams, the effects of caffeine on aquatic species need to be considered.

Although caffeine is frequently used, there are some serious side effects if used in excess. Some studies have shown that the side effects to humans are similar to other species and plants. It can cause insomnia, nervousness, stomach irritation, and increased heart rate and respiration. Caffeine can also aggravate anxiety disorders and bleeding disorders. It has also been shown to increase blood pressure and weaken bones.⁶ Also, caffeine is a diuretic, which causes more frequent urination.

There have been some studies on the effects of caffeine on specific species. The northern leopard frog displayed behavioral and physiological effects when exposed to caffeine. Exposure to high concentrations of caffeine also caused a change in oxygen consumption by sea urchin fertilized eggs and impaired reproduction of a water flea species. Most studies conducted on the effects of caffeine on aquatic species have used high concentrations of caffeine that do not represent the environmental concentrations.⁷ The effects caused by long term exposure of lower concentrations need to be further studied to gain a better understanding.

The chemical properties of caffeine are important to understand its environmental fate in aquatic systems. The log octanol-water partitioning coefficient (Log Kow) is the ratio of the molar concentration found in octanol verse water, which suggests the chemicals biodegradability and solubility. In general, the larger the Log Kow, the lower the solubility, the higher the log bioconcentration factor (Log BCF) and the water partition coefficient (Koc).⁸ The Log Kow for caffeine is -0.07, which indicates that caffeine is very soluble and biodegradable.⁹ This value, shown in Table 1, indicates that caffeine will not adsorb to solids present in an aquatic system. The Log BCF, refers to the uptake of a chemical from water by respiration or dermal contact. It is calculated using the Log Kow value, and values less than 3 are considered nonbioaccumulative, between 3 and 3.7 are considered bioaccumulative, and greater than 3.7 are considered very bioaccumulative. The Log BCF in aquatic organisms is low for caffeine, with a value of 3.¹⁰

Caffeine is removed with biological treatment and in rivers and streams. Activated sludge treatment has proven to be effective in removing caffeine since it is readily biodegradable.¹⁰ This study will compare the concentrations of caffeine before and after trickling filter biological treatment at Central Valley to determine if this facility correlates to other studies.

Cocaine/Benzoyllecgonine (BE)

Cocaine is an alkaloid ester that is extracted from coca plants. Cocaine will increase the heart rates and blood pressure while constricting the arteries. This often leads to heart attack or causes arrhythmia. Constricted blood vessels in the brain cause strokes, seizures, and bizarre and violent behavior. Constriction of vessels in the stomach leads to ulcers or perforation of stomach or intestines. Cocaine has also been known to impair sexual function.¹¹ Benzoyllecgonine (BE) is the main metabolite formed when cocaine is consumed and contributes to many of the side effects of cocaine. The chemical properties of benzoyllecgonine are displayed in Table 1.

When cocaine is released into water, it is likely that it will adsorb to suspended solids or sediments due to its Log Kow value. The Log Kow for cocaine is 2.31, implying that cocaine is slightly water soluble and biodegradable. The Log BCF of cocaine is 3, which indicates it has a low bioconcentration in aquatic species. At a pH of 7, the cocaine half-life is 54 years.¹²

Cotinine

Cotinine is the primary urinary metabolite of nicotine. It is detected in urine to determine the concentration of nicotine consumed by tobacco smokers, and is also found in urine of nonsmokers exposed to second hand smoke.

Cotinine has a vapor pressure, shown in Table 1, which indicates it will be present in both vapor and particulate form in the atmosphere, compared to nicotine which is completely vaporized in the atmosphere. Thus, second hand smoke is more likely to contain particles of cotinine, which will show a higher presence in urine tests than nicotine.¹³ Studies have not shown any dangerous effects of cotinine in humans but the effects of nicotine have been proven to be quite dangerous.¹⁴ Nicotine can cause a faster and pounding heartbeat, extreme weakness, nausea, vomiting and wheezing. Tightness in the chest, stinging in the nose, throat and mouth, blisters in the mouth, and nose bleeds are also caused by nicotine. Life threatening coronary artery vasoconstriction and bronchospasms are dangerous symptoms of nicotine use.¹⁵ Although cotinine does not cause physical side effects, it does cause serious withdrawal symptoms, which makes it one of the most difficult addictions to conquer. There are drug detection kits available for nicotine detection, but cotinine detection was chosen because it is much more prominent in urine samples and easier to detect in diluted sources such as wastewater.

Cotinine released into the environment by smoke vapor which will either degrade in the atmosphere or will be removed by wet or dry deposition. The Log Kow of cotinine indicates it will be highly mobile in soil, but it will not be adsorbed by suspended particles in water systems. Instead, cotinine will most likely be biodegraded in the system. The Log BCF for cotinine is 3, which indicates that the bioconcentration in

aquatic species is low.¹³ A Log Kow of 0.07 for cotinine indicates that it is quite water soluble.¹⁶

Methamphetamine/MDMA

Methamphetamine (meth) elevates dopamine levels in the body, up to 12 times higher than food or sexual intercourse. Meth destroys dopamine sensors, thus, making it impossible to feel pleasure. Meth also destroys tissues and blood vessels, causes acne, loss of elasticity and luster in skin and tooth decay by drying out salivary glands which allows acids in the mouth to eat away teeth enamel.¹⁷

MDMA, or 3, 4-methylenedioxy-N-methylamphetamine, is commonly known as ecstasy. It is a popular drug linked to raves and electronic music. MDMA binds to the serotonin transporter which, prolongs the serotonin signal. This causes excessive release of serotonin from neurons which causes heightened senses and euphoria. It can also cause confusion, depression, sleep problems, drug cravings, and severe anxiety. MDMA increases heart rate, blood pressure, causes muscle tension, involuntary teeth clenching, nausea, blurred vision, faintness, chills, sweating, and hypothermia.¹⁸

Meth has a wide range of Koc values, as seen in Table 1. These values are relatively low, indicating that meth is unlikely to be adsorbed by particles and sediments in water systems. The Log BCF for meth is 2, which means the bioconcentration in aquatic species is very low. The Log Kow is 2.07 meaning meth is somewhat hydrophobic.¹²

Nandrolone

Nandrolone, also known as Deca-Durobolin, is an anabolic steroid which is produced naturally by the human body, but only in very small concentrations. Nandrolone is very similar to testosterone, except it is more anabolic than androgenic, which indicates nandrolone would be beneficial for muscle building without increasing male sexual characteristics. It has been used by athletes as a performance enhancer because it can increase muscle mass without an increase in body hair or aggressive behavior associated with using testosterone as a steroid. Nandrolone can still cause many problems if abused. Fluid retention, edema, congestive heart failure, and sexual problems may persist. Genitourinary effects including oligosperma, infertility, decreased ejaculatory volume, and an enlarged prostate can occur in men using nandrolone. Women may experience a deepening of the voice, hirsutism or excessive hair growth, acne, or clitoromegaly, which is the enlarging of the clitoris.¹⁹ The International Olympic Committee set a limit of 2 ng/mL of urine as the maximum concentration produced naturally. Some athletes have had concentrations 100 times greater than this.²⁰

Since nandrolone is a hormone, excessive concentrations in aquatic systems can have detrimental impacts on aquatic species. Studies have shown that exposure to some hormones in aquatic systems have direct effects on the gonads, reproductive systems, and sexual differentiation during early development. The effects of nandrolone have not been highly studied, but it can be assumed that the impacts caused by other androgenic hormones are a good indication that any hormone exposure is harmful to aquatic species.²¹

The Koc value of nandrolone assumes that nandrolone is likely to adsorb to particles and sediments in water bodies. The Log BCF of nandrolone is 21, indicating that the bioconcentration in aquatic species is low.¹³ Nandrolone is somewhat water soluble, with a Low Kow of 2.62.⁸

Oxycodone

Oxycodone is a narcotic, or an opioid, pain reliever. Oxycodone, found in OxyContin, has become a highly abused prescription drug. The side effects of oxycodone include drowsiness, sedation, respiratory depression, apnea, intestinal obstruction, and anxiety. Withdrawal symptoms are also a common side effect of oxycodone. If too much is taken, hallucinations, psychosis, and slowing of the heartbeat can occur.²²

Oxycodone is not expected to be adsorbed by suspended particles or sediments in water bodies due to the low Koc value. The Log BCF for oxycodone is 3, which means it has a low bioconcentration in aquatic species. A Log Kow of 0.7 implies that oxycodone is quite water soluble.¹³

THC

Tetrahydrocannabinol, more commonly known as THC, is the main compound found in marijuana. It influences pleasure of memories and thinking, concentration, sensory and time perception and coordination. Chronic users show more impacts to memory loss that can last for weeks.²³ Although there are risks, THC is becoming more popular in the medical industry as an antiemetic, which is a drug used to reduce nausea, and as an appetite stimulant. As more states begin to legalize marijuana, not just for

medical use but also for recreational use, it will become more prominent in the wastewater streams.

If THC is released into a water system, it is expected to be adsorbed onto suspended particles and into sediments due to its high K_{oc} value. THC is expected to volatilize from water surfaces because of its Henry's Law constant: $2.4 * 10^{-7} \frac{(atm-m^3)}{mole}$. The Log BCF for THC is very high, indicating that the bioconcentration in aquatic species is also very high.¹³ THC has a high Log K_{ow} , 6.48, indicating that it is more hydrophobic than other drugs.²⁴

How do Drugs Enter the Wastewater System?

Only a portion of what is consumed is used by the human body. This includes all drugs. The components that remain unused are excreted in urine or feces in the parent or metabolized form. The amount excreted depends on the dose, the frequency of use, and the person's individual metabolism. Many drugs can be detected in urine post-ingestion for 1.5 to 4 days with just a single dose. Drugs can be detected for up to a week after the last dose in chronic users. Specifically, cocaine and THC can remain in the system for even longer periods of time. The limit of detection varies for each drug as well. The limit of detection of meth in urine is approximately 2.5 ng/ mL, while THC is 10 ng/mL.²⁵

In 2010, it was estimated from a survey that 6.24% of Utah residents used illegal drugs in the past month, with 3.12% reporting the use of a drug other than marijuana. Almost 7000 Salt Lake County residents were admitted for substance abuse rehabilitation in 2009. In 2007, 546 people passed away from a drug-induced death, which is more than

the 320 who died from vehicle accidents and 253 from firearms in the same year.^{26, 27} The number of illicit drug users in the state is most likely higher than surveys suggest. Many residents will not fill out surveys, and others will not respond honestly about drug usage.

The numbers shown in surveys suggest that there are still high volumes of drugs being used in Salt Lake County and they are entering the wastewater system. Using the concentrations found in wastewater would help local law enforcement determine a more accurate amount of drugs being used in Salt Lake County. These concentrations also help the wastewater treatment facility determine what further treatment is necessary to reduce the quantity of drugs entering the Jordan River.

Possible Impacts from Drugs of Abuse in Wastewater

Very little is known about the effects of drugs on aquatic species. The effects of specific drugs on humans are fairly well known, and it may be assumed that these effects will be similar to other species. Only a few studies have been performed on living specimens, with many being mammals. The few studies that have been conducted need to be considered when developing wastewater treatment methods to remove drugs from wastewater.

A study performed by Castiglioni et al., on zebrafish is one of the few reports on the effects of illicit drugs on aquatic species.²⁸ Zebrafish and zebrafish embryos were exposed to various drugs at different concentrations to determine the effects. When the zebrafish were exposed to 5 mg/L of cocaine, the fish would slowly circle at the bottom of the water column with their fins extended, which indicates arousal. The zebrafish

embryos were also exposed to THC, which reduced the amount of spontaneous tail muscle twitches that occur during development. At concentrations near 2.0 mg/L, the spine would curve and the tips of the tails would form a bulbous shape. At concentrations above 2.0 mg/L of THC, the embryo would die. Additionally, when zebrafish were exposed to 100 mg/L of nicotine for 3 minutes, they displayed a significant decrease in diving. When exposed to 50 mg/L for longer periods of time, the zebrafish would tend to dwell at the bottom of the water column.²⁸

Studies on mammals have been conducted to determine how the drug will possibly affect humans. One study on primates showed that the effects on the serotonin nerves after a 4 day exposure to MDMA could last 6 to 7 years.¹⁸

Insects have also been exposed to drugs to understand the impacts. Walters performed a study on *Drosophila melanogaster*, a common fruit fly, using methamphetamine, to determine how it affects the species. The flies exhibited anorexic behavior when exposed to meth for several hours. The flies also displayed increased movement and activity, similar to humans, when exposed to meth.²⁹

Although these studies were performed with high concentrations of drugs, the effects are critical to understanding how the concentrations seen in the environment can affect the ecology. The concentrations will continue to rise in the environment as the human population grows and more people use illegal drugs. Also, the species exposed to the drugs are continuously exposed, not for just short periods of time. These long term exposures can have even more detrimental effects to the surrounding environment. More

studies on the species specific to the areas of contamination, including plants and migratory birds, should be performed to determine long term effects of drug exposure.

Current Detection Methods

Chromatography is the main method used to detect drugs in liquid samples. The sample mixture is separated between two phases: a stationary phase and a mobile phase. The stationary phase is typically fixed in place while the mobile phase carries the mixture through the medium of the stationary phase. The mixture is controlled by the interactions between the mixture's components and the stationary and mobile phases. Some of the components will slow and interact with the stationary phase, while others will increase in speed and remain interacting with the mobile phase. The difference in the velocities controls the separation of different species in the mixture. The mobile phase will carry the separated species away from the stationary phase at different times, which can be measured to determine which species are present in the mixture.

The stationary phase of chromatography is typically a substance coated on the interior walls of the column. There are different types of columns: open tubular, capillary, or packed column. The columns can have a variety of stationary phases and polarities and are chosen based upon the sample mixture and species that are being detected. The mobile phase is determined by the type of chromatography used and the column chosen. Figure 1 is an example of a chromatographic system.

There are two types of chromatographic methods, gas-chromatography and liquid-chromatography. Both are commonly used to detect drugs in liquid samples.

Gas-chromatography (GC) uses a gas carrier as the mobile phase. When samples are injected into the GC, they are heated and converted into their vapor phase. The carrier gases commonly used are helium, argon, or nitrogen. The carrier gas will transfer the sample in vapor form to the stationary phase, which is typically a packed column. The individual species will interact with the stationary phase at different rates, as discussed above. When the gas exits the column, a detector will determine the species in the sample. There are many detectors available to be used with a GC. The most common detector used for drug detection is a mass spectrometer (MS). The GC will separate the compounds from each other, and the MS will identify each species by the fragmentation after chemical or electron ionization.³⁰

Liquid-chromatography (LC) uses a liquid for the mobile phase. The liquid is chosen based on the stationary phase used, which is chosen based on the compounds being detected. Sodium chloride, methanol and water mixture, n-heptane, or ethanol are common examples of mobile phases that are used. A liquid sample that has been concentrated and resuspended in a compatible solution is injected into the LC. The sample and mobile phase liquids are transported through the LC column, interact with the stationary phase, and are then transported to the detector to determine which species are present. There are several detectors compatible with LC, but a tandem MS detector is the most commonly used for drug detection.³¹

Many studies have used other forms of GC and LC for drug detection to determine which method is most effective. High performance liquid chromatography (HPLC) has higher pressures within the column, forcing the solvent through and

completing detection at much faster rates. A high performance liquid chromatography system with tandem mass spectrometry (HPLC-MS/MS) is often used to detect drugs at higher concentrations. The high performance liquid chromatography-atmospheric pressure ionization (HPLC-API-MS) uses chemical ionization at atmospheric pressure to detect drugs. Solid phase extraction (SPE) is commonly coupled with HPLC-MS/MS for accurate drug detection in urine. Ultra performance liquid chromatography (UPLC) uses high pressures, similar to HPLC, coupled with increased sensitivity and resolution for even faster detection rates and high accuracy.^{32, 33, 34}

Although the use of chromatography provides accurate results for drug concentrations in liquid samples, it is quite expensive and time consuming. A chromatography machine can cost from tens to hundreds of thousands of dollars. Many wastewater treatment facilities may have a chromatography systems, but new columns specific to each drug tested would need to be purchased. With multiple collection sites, the facility may want to use several machines at once to be more time efficient. The facility may want to consider investing in multiple detectors because the composition of wastewater may damage the machine. This can be a substantial initial cost for wastewater treatment facilities to begin detecting illegal drugs in wastewater.

Another concern with detection of drugs in water and wastewater is the time for sample preparation. After samples are collected, they need to be filtered and concentrated. This process can take several hours per sample due to the high amount of suspended solids in raw wastewater. Running the sample through the GC or LC can take several hours as well. A lab technician would have to work several days continuously to

process and test one sample. It would be more convenient for wastewater treatment operators and inspectors to be able to test the samples and have accurate results within a couple hours of collection, rather than waiting a few days for results.

Current Treatment Methods

Although illegal drugs are currently not regulated by the U.S. Environmental Protection Agency (EPA), conventional wastewater treatment methods partially remove drugs from the system. Studies on the removal rates from various treatment methods have been examined and are discussed below.

A research project in the United Kingdom tested wastewater from two rivers and two wastewater treatment facilities for amphetamines, cocaine, and BE. Using UPLC-MS, the study found that there were high concentrations of all three drugs present in the rivers. The cocaine metabolite, BE, was found in concentrations up to 10 times higher than the parent chemical. In both wastewater treatment facilities, activated sludge removed up to 100% of amphetamine, cocaine and BE, while the trickling filter only removed 95% of amphetamine, 25% of cocaine, and there was no noticeable removal of BE.³⁵

Zuccato et al. examined removal rates in wastewater treatment facilities of illegal drugs. One study found that 85 to 99% removal of methamphetamine occurred while another study showed 60 to 98% removal, resulting in low concentrations (ng/L) in the effluent. MDMA was found to be removed at rates from 44 to 57%, with approximately 0.10 ng/L in the effluent. Cocaine and BE both were found to have approximately 10% of

the influent concentration remaining in the effluent after wastewater treatment. THC had the most extreme removal rate range, from 11 to 99% removal. Studies also showed that removal rates were higher in 2006 than in 2004. This is most likely due to improved treatment methods.³⁶ Concentrations ranges detected in wastewater influent, effluent and receiving waters are displayed in Table 2.

From the little research performed, it can be suggested that bioreactors can remove higher quantities of drugs from wastewater systems. Although a portion of the drugs are removed, the concentrations being released are still of concern due to possible effects on the environment.

Use of Reclaimed Water and Drug Effects

With growing populations and limited water resources, use of reclaimed water is gaining importance. If the reclaimed water is supplied from a municipal wastewater discharge area, such as a lake, river, or groundwater, drinking water may be contaminated with the drugs that are not removed during wastewater treatment.

In Spain, the surface waters of the Ebro River and the tap water in Barcelona were tested for various drugs including methamphetamine, MDMA, THC, cocaine and BE. The most concentrated compound found was BE, at levels as high as 346 ng/L in the surface water. In drinking water, 130 ng/L of BE and 1.7 ng/L of meth was detected.³⁷

Zuccato et al. also discussed drinking water treatment removal rates of specific drug compounds. Amphetamines were found to be almost completely removed during treatment by prechlorination, flocculation, and sand filtration. Granulated activated

carbon (GAC) removed 100% of cocaine, 88% of MDMA and 72% of BE. In 22 of the 24 samples taken from the treated drinking water, BE was found in concentrations ranging from 45 ng/L to 130 ng/L.³⁶

A study in Barcelona proved that groundwater is being contaminated by drugs of abuse as well. Groundwater infiltration is not removing the drugs from the wastewater. Thirty-six groundwater samples from the Barcelona urban groundwater system were tested for cocaine, BE, THC, methamphetamine, and MDMA. The concentration ranges are shown in Table 3. Approximately 40% of the United States uses groundwater for drinking water. If groundwater recharge areas are supplied with treated wastewater contaminated with drugs, and the local municipalities use the groundwater as a culinary source, the drinking water could be at risk for drug contamination.³⁸

Drinking water treatment methods need to be improved to ensure that the drugs are completely eliminated. It is alarming that traces of BE were found in all of the water samples. More research is necessary to determine what methods could be implemented to effectively remove BE from all of the water systems. The general public would be very concerned if the culinary drinking water had any traces of illegal drugs. As reclaimed water becomes more popular as a main drinking water source, the concentrations of illegal drugs need to be reduced to nonexistent levels to protect society from consumption.

The previous information indicates that drugs are prevalent in the water system and if not properly treated, could impact the environment and future societies that use reclaimed water as a drinking source. Although not currently regulated by the EPA, it

would be beneficial for wastewater treatment facilities to begin testing for drugs of abuse to determine what concentrations are present and the facilities' removal rates. This data could be used to help the facility begin to plan for additional treatment methods when the EPA does implement regulation. As most treatment facilities are government based and have limited funding, a method to detect illegal drugs in the wastewater that is cost and time effective that does not require gaining permits from the DEA will allow municipalities to begin testing and preparing for drug removal.

Table 1 - Drug Physical and Chemical Properties

	Benzoyllecgonine	Caffeine	Cocaine	Cotinine
Chemical Composition	$C_{16}H_{19}NO_4$	$C_8H_{10}N_4O_2$	$C_{17}H_{21}NO_4$	$C_{10}H_{12}N_2O$
Chemical Structure				
Molecular Weight (g/mol)	289.33	194.1906	303.35294	176.21508
Vapor Pressure (mm Hg @ 25°C)	3.77×10^{-11}	7.3×10^{-9}	1.91×10^{-7}	3.8×10^{-4}
Koc	1.28	22	-	130
Henrys Constant (atm-m³/mole)	1.03×10^{-13}	3.6×10^{-11}	4.2×10^{-11}	3.3×10^{-12}
pKa	2.15	10.4	-	-
Half Life in Water	-	0.8 days	54 yrs. at pH 7 5 yrs. at pH 8	-
Log BCF	1.00	3	3	3
Log Kow	-1.32	-0.07	2.31	0.07
	Meth	MDMA	Nicotine	Nandrolone
Chemical Composition	$C_{10}H_{15}N$	$C_{11}H_{15}NO_2$	$C_{10}H_{14}N_2$	$C_{18}H_{26}O_2$
Chemical Structure				
Molecular Weight (g/mol)	149.2328	193.2423	162.23156	274.39784
Vapor Pressure (mm Hg @ 25°C)	1620	0.003	0.0038	3.5×10^{-8}
Koc	9 to 22	-	100	630
Henrys Constant (atm-m³/mole)	7.34×10^{-3}	2.75×10^{-9}	3.0×10^{-9}	2.7×10^{-9}

Table 1 (cont)

	Meth	MDMA	Nicotine	Nandrolone
pKa	11	-	-	-
Half Life in Water	1.0 Hrs. in river 3.9 days in lake	-	-	-
Log BCF	2		3	21
Log Kow	2.07	-0.32	1.2	2.62

	Oxycodone	THC
Chemical Composition	$C_{18}H_{21}NO_4$	$C_{21}H_{30}O_2$
Chemical Structure		
Molecular Weight (g/mol)	315.36364	314.4617
Vapor Pressure (mm Hg @ 25°C)	2.2×10^{-10}	4.6×10^{-8}
Koc	120	3.3×10^5
Henrys Constant (atm-m³/mole)	-	2.4×10^{-7}
pKa	8.3	-
Half Life in Water	-	-
Log BCF	3	5
Log Kow	0.7	6.48

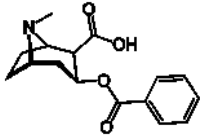
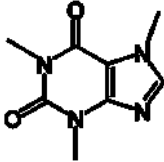
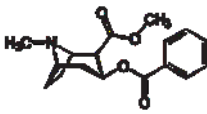
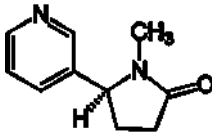
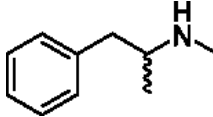
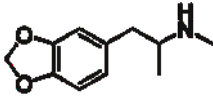
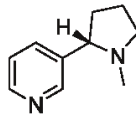
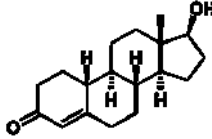
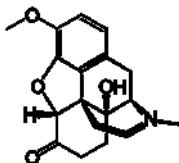
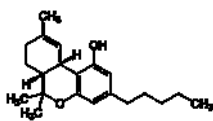
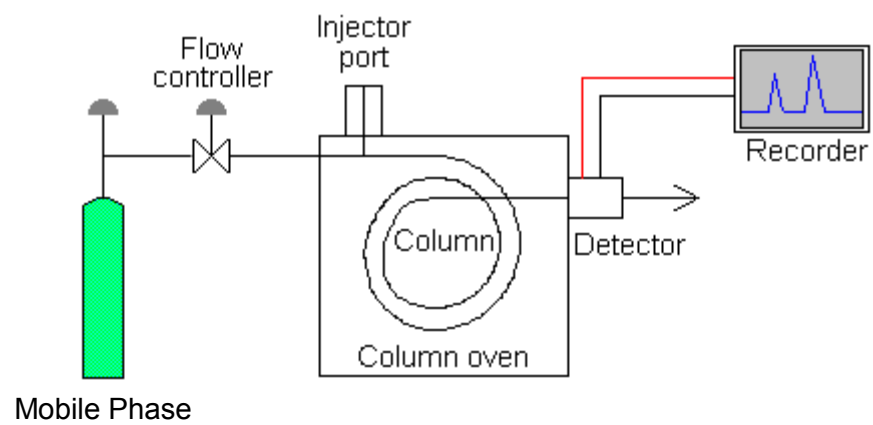

Figure 1- Chromatographic Process Schematic

Table 2 - Concentration Ranges of Illegal Drugs Detected in Recent Publications

Drug	Target Chemical	Influent Concentration (ng/L)^{39, 40}	Effluent Concentration (ng/L)⁴¹	Surface Water Concentration (ng/L)⁴²
Oxycodone	Opioid narcotic; pain reliever	ND - 220	ND	NA
Cotinine	Nicotine by-product; tobacco	ND - 6820	ND - 2726	ND - 516
Cocaine	Central nervous system stimulant	79-860	ND - 47	ND - 10
Caffeine	Stimulant	ND - 120000	ND - 22848	ND - 2991
THC	Active chemical in marijuana	NA	NA	NA
MDMA	Ecstasy	13.6 - 91	ND - 67	ND - 3.5
Nicotine	Tobacco	NA	NA	NA
Benzoylcegonine	Cocaine metabolic by-product	0.08 - 2800	ND - 928	ND - 111
Meth	Stimulant	ND - 2000	ND - 3.5	NA
Nandrolone	Anabolic Steroid	ND - 2.4	ND - 1.2	ND - 0.60

Table 3 - Concentrations of Illegal Drugs Detected in Groundwater in Barcelona

Drug	Average Concentration \pm Standard Deviation (ng/L)³⁸	Max Concentration (ng/L)³⁸
Cocaine	3.8 \pm 12.8	60.2
BE	1.5 \pm 4.5	19.6
THC	-	-
Meth	-	-
MDMA	3.9 \pm 6.6	36.8

CHAPTER 3

MATERIALS AND METHODS

The objective of this study was to develop a cost and time effective method to detect drugs of abuse in wastewater. Research was conducted on sewage and treated wastewater from Central Valley Water Reclamation Facility and adjoining collection agencies in Salt Lake City, Utah. The samples were processed for testing with Neogen ELISA forensic drug detection kits. The Neogen kits were used to detect caffeine, cocaine/BE, cotinine, meth/MDMA, nandrolone, oxycodone, and THC. The materials and methods used are discussed below.

Sample Collection

Sewer Lines

Samples were collected from the Salt Lake Valley wastewater sewer systems and Central Valley Water Reclamation Facility (CVWRF) in Salt Lake City, Utah. Eight sewer lines feed Central Valley from seven improvement districts: Cottonwood Improvement District, Granger-Hunter Improvement District, Kearns Improvement District, Murray City, Mt. Olympus Improvement District (formerly known as Salt Lake Suburban Sanitary District One, has two sewer lines), South Salt Lake City, and

Taylorsville-Bennion Improvement District. Figure 2 displays the boundaries of these improvement districts. Combined, these districts serve over 500,000 people and cover approximately 94 square miles.⁴³

Each sewer line has a sampling station located before it merges with other districts' sewer lines and enters CVWRF. A permanent pump is located at each sampling station and samples are randomly taken daily for CVWRF testing. These pumps were used manually to collect the samples into 1 L amber glass bottles. The glass bottles were labeled, sealed, and stored in a cooler with ice packs.

Wastewater Treatment Facility

Central Valley Water Reclamation Facility Board was established in 1978 in response to the Clean Water Act. The members of the board represented the five original wastewater treatment facilities. Central Valley was designed to treat 75 million gallons of wastewater a day.⁴³ Figure 3 is a schematic of Central Valley's wastewater treatment process.

A conventional wastewater treatment plant has many components, as shown in Figure 3. Untreated wastewater enters the treatment facility through a network of sewer lines. The preliminary treatment includes bar screens, which capture any large debris that will be collected and removed. Sewage is then pumped into aerated grit chambers where smaller particles, like sand, are removed. Water is then transported to primary sedimentation, where the heavier solids are given time to settle to the bottom of the tank. During this process, the oils and fats are skimmed off of the surface, and 60% of the settleable material has been removed. Next, wastewater is pumped to trickling filters,

where biological growth degrades pollutants. After the trickling filter, the water is transported to the solid contacts (aeration) tanks. In this process, the growth of microorganisms converts remaining pollutants into settable solids. The wastewater and biosolids flow into the secondary sedimentation tank, where solids form and settle to the bottom of the tank. At this point, 95% removal of pollutants is observed. Wastewater is then sent to disinfection, using chlorination to kill any disease causing bacteria. The water flows through aeration tanks, where dissolved oxygen is diffused into the water before it is discharged to Mill Creek.

The sampling locations chosen within Central Valley were the trickling filter, solids contact, and final effluent. The trickling filter and solids contact were chosen because they have very high removal rates of most contaminants. The effluent was tested to make a comparison of the final concentration of drugs to those found in the sewage lines. Samples collected at the trickling filter were taken after the first filter, and those from the solids contact were taken from the second tank. Effluent was taken at the discharge point, before the water merges with Mill Creek.

All samples collected within the plant were taken by using a bucket attached to a pole, which was rinsed with the water at the sampling location prior to collecting each sample. Samples were then poured into 1 L amber glass bottles, previously muffled at 550 °C for 6 hours, which were sealed, labeled, and stored in a cooler with ice packs. The samples were then refrigerated and processed within 24 hours of collection.

Sample Processing

Samples were filtered using a 1.2 micrometer glass fiber filter within 24 hours of collection. At least 500 mL of sample was filtered. Organics from the filtrate were concentrated on a hydrophobic resin (C-18, octadecylsilane, Empore). Organics were eluted from the C-18 disk with 20 mL of ethanol, after which the volume was reduced and the analytes were re-constituted in water or buffer. Appendix A displays instructions for sample processing for each drug kit.

Immuno-Assay

Current analytical methods used to detect drugs in the wastewater are expensive and very time consuming. Affordable products are available for drug testing from human urine, blood, and saliva that are relatively quick to perform and are very efficient. Testing wastewater samples with the assay could greatly reduce time and costs for treatment facilities to begin monitoring and reporting drugs of abuse.

Drug kits used for this experiment were purchased from Neogen Corporation. The kits cost \$160 each and only take a couple hours to perform. Each kit contains 96 reactions, at \$1.67 per well on the assay plate. Including the standard curve, a sample can be analyzed for under \$30. On the other hand, quantification of opioid drugs in 1L of water costs \$800-900 as quoted by the U.S. Geological Survey.⁴⁴

Enzyme-linked immunosorbent assays (ELISA) use antibodies, antigens and enzymes to determine the concentrations of drugs. The 96-well assay plates are coated with immobilized antibodies that are specific to the antigen of the drug being tested.

There are a limited number of antibodies on the plates, controlling the number of antigen binding sites. This limitation restricts the concentration ranges that can be detected.⁴⁵

The wastewater sample and drug conjugate were added to the wells and incubated for a specified amount of time. A metalloenzyme from the root of horseradish, horseradish peroxidase, is used as the drug conjugate. Horseradish peroxidase uses hydrogen peroxide to oxidize organic and inorganic compounds. When reacted with specific substrates, bright colors are produced. Using various wavelengths, “transparent” proteins that are bound to an enzyme substrate can be detected. For the Neogen test kits, the drug-horseradish peroxidase conjugate competes with the drugs in the sample to bind to the antibodies that are immobilized to the plate during incubation. The higher concentration of drug present reduces the amount of enzyme conjugates that can bind to the plated antibodies.⁴⁶

After incubation, the wells are washed to remove any unreacted conjugate and sample. A K-Blue Substrate of 3, 3', 5, 5' Tetramethylbenzidine (TMB) and hydrogen peroxide (H_2O_2) is then used to react with the unconjugated enzyme for color development. This reaction produces a blue pigment in the solution. The higher concentration of horseradish peroxidase, the brighter the solution becomes. After 30 minutes of substrate interaction with enzyme conjugate, acid, typically sulfuric acid, is added to each well to stop the reaction. The absorbance is then read to determine the concentration of the drugs compared to the concentration of conjugate in each well. Samples that have high concentrations of drugs will have lower absorbance because there is less reaction occurring between the enzymes and substrates. Figure 4 displays the color

variation due to concentration ranges when K-Blue Substrate has reacted. The dark blue wells show little to zero concentration of drug, while the light blue to clear wells indicate high concentrations of drug. Figure 5 displays a plate with a different chromogenic substrate that has reacted with acid. The dark yellow color indicates low concentrations while the clear wells indicate high concentrations of drug detected. Figure 6 is an example of the process used for the Neogen Kits.⁴⁷

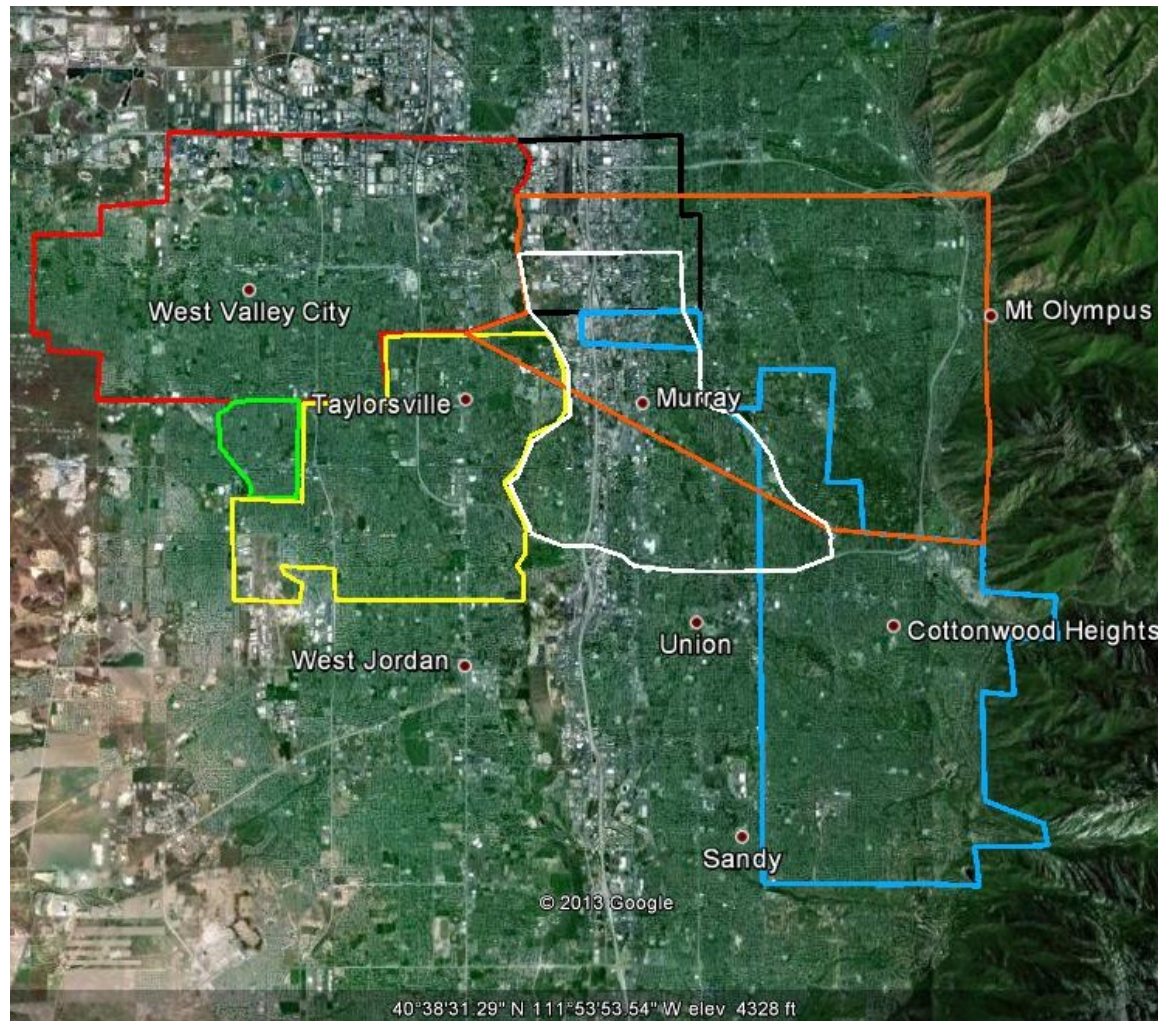

Legend

- Cottonwood Heights Improvement District
- Granger-Hunter Improvement District
- Kearns Improvement District
- Mt. Olympus Improvement District
- Murray City
- South Salt Lake City
- Taylorsville-Bennion Improvement District

Figure 2- Map of Central Valley Improvement Districts

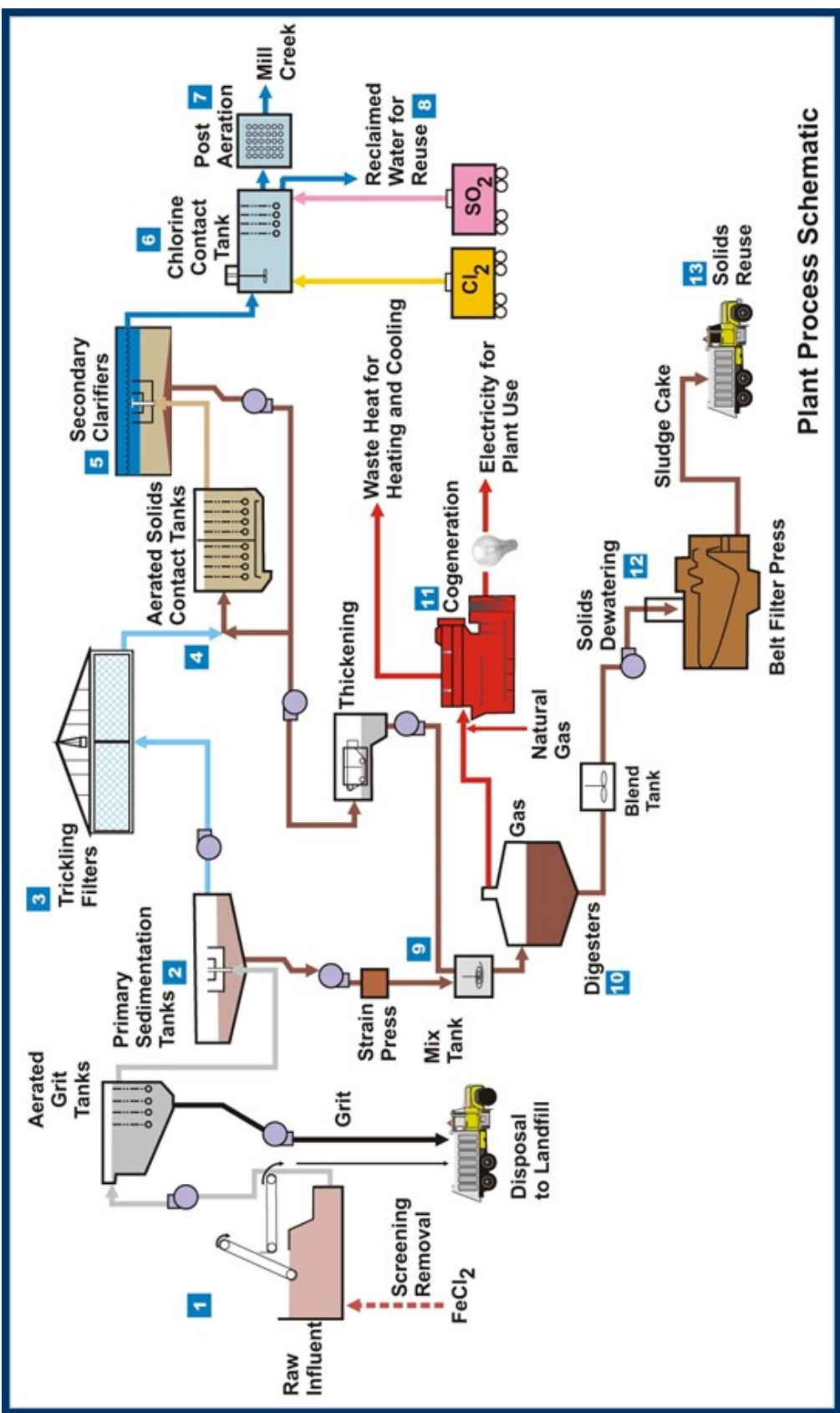

Plant Process Schematic

Figure 3 - Central Valley Water Reclamation Facility Schematic

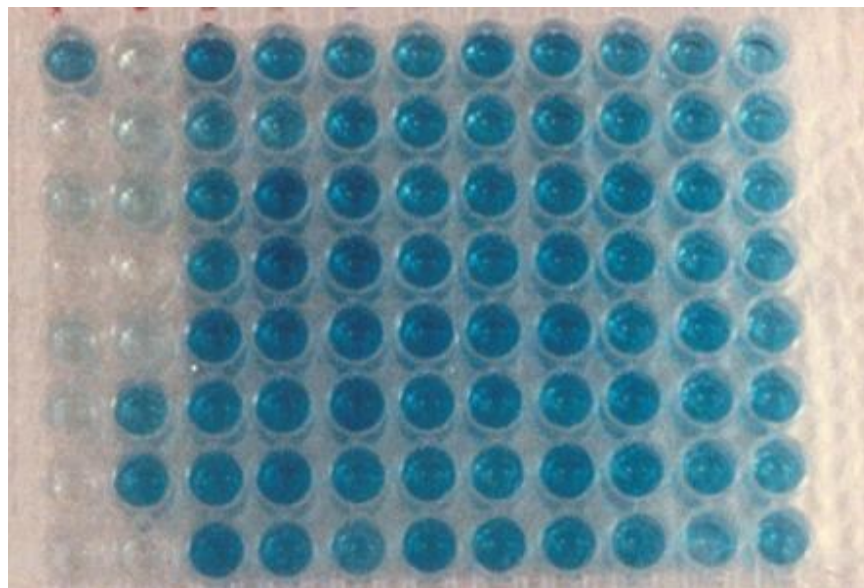

Figure 4 - Color Variation Related to Concentration when K-Blue Substrate is Added



Figure 5 - Color Variation Related to Concentration after Acid is Added

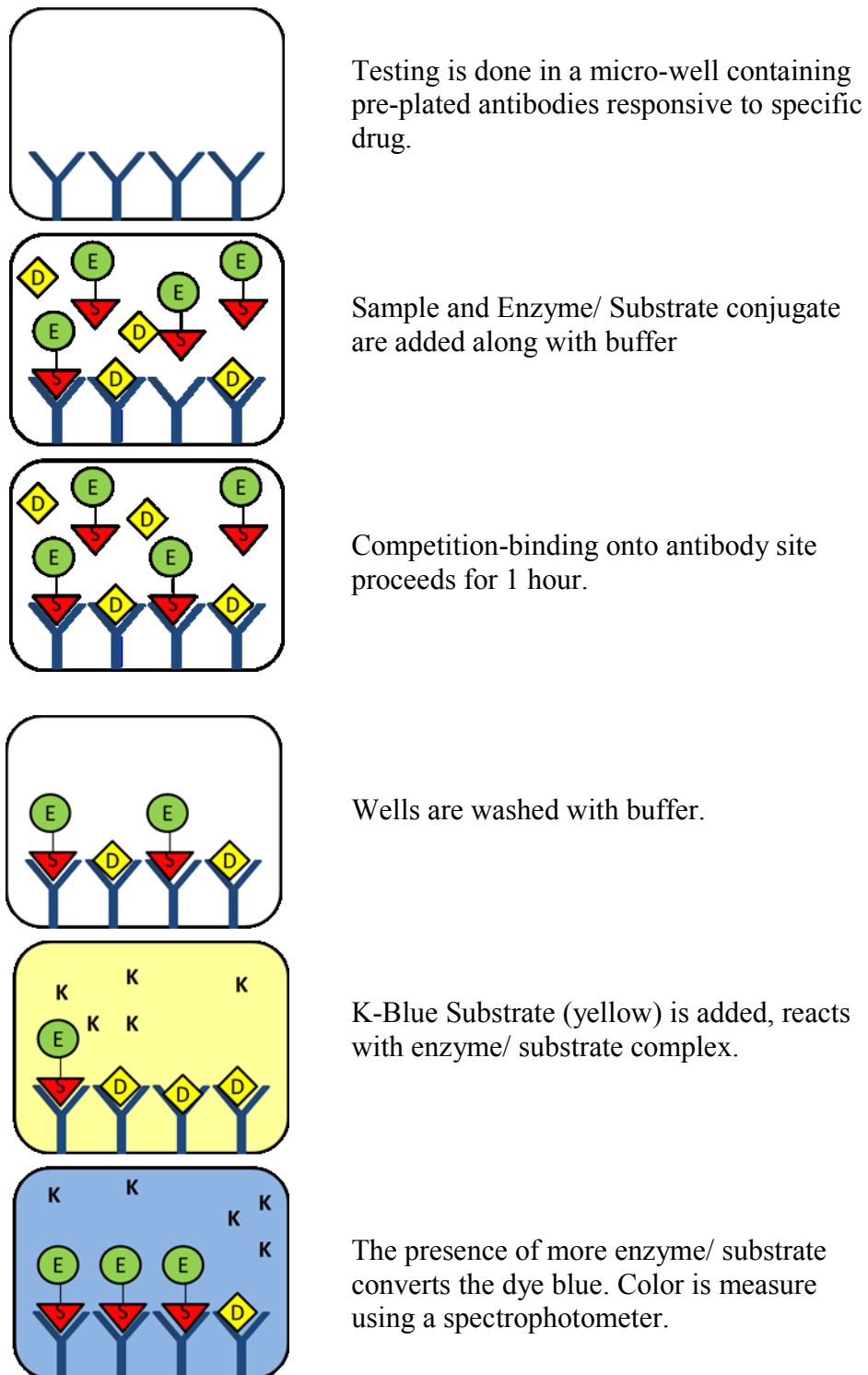

Figure 6 - Immuno-Assay Reaction Process

CHAPTER 4

RESULTS

Introduction

A standard curve was developed for each drug kit used. The standard curves were used to determine the concentration of drug at each sampling location. The results for each drug are discussed below.

Caffeine

Wastewater samples used for caffeine testing were filtered and diluted two-fold. An unfiltered sample was processed to compare to the filtered results. Samples were tested in triplicate. Figure 7 shows the standard curve developed for caffeine. The standard curves were developed by running tests using the positive (approximately 100 $\mu\text{g/L}$) and negative controls supplied in the Neogen kit. The ratio of the wavelength of known concentration over the wavelength of the negative sample were found and used to scale the y-axis. Thus, at higher concentrations, the ratio would be a smaller value. To develop a more precise standard curve, an exact caffeine standard would be more appropriate. The standard curve was developed for each using the positive and negative

controls supplied to determine if it would provide the necessary results to establish the approximate drug concentrations.

Table 4 displays the approximate concentrations found in the sewage and wastewater samples. The concentrations found in the samples from the sewage lines that were filtered through 1.2 μm glass fiber range from 70 to 168 $\mu\text{g/L}$. The samples that were unfiltered had a concentration range of 90 $\mu\text{g/L}$ to 194 $\mu\text{g/L}$. Caffeine levels decreased after the trickling filter (1 $\mu\text{g/L}$), solids contact (1.5 $\mu\text{g/L}$) and effluent (0.5 $\mu\text{g/L}$).

Cocaine

Samples for cocaine/BE analysis were processed without being diluted or concentrated. The concentration ranges found in wastewater fell within the limits of the Neogen detection kits. The samples for cocaine testing were filtered and ran in triplicate. Figure 8 displays the standard curve developed for cocaine. A 300 $\mu\text{g/L}$ urine cutoff calibrator supplied with the Neogen kit was used to develop the standard curve.

The concentrations of cocaine found in wastewater are listed in Table 5. Concentrations ranged from 1 $\mu\text{g/L}$ to 51 $\mu\text{g/L}$ in the 1.2 μm glass fiber filtered samples from the sewer lines, while raw samples showed concentrations ranges of 42 $\mu\text{g/L}$ to 73 $\mu\text{g/L}$. The concentrations after treatment showed a slight decrease. The trickling filter had a concentration of 44 $\mu\text{g/L}$ for the filtered sample, and 65 $\mu\text{g/L}$ for the raw sample. The solids contact had concentrations of 37 $\mu\text{g/L}$ and 40 $\mu\text{g/L}$ for the unfiltered sample. The effluent concentration of the filtered sample was 20 $\mu\text{g/L}$ and the raw sample was 33

$\mu\text{g/L}$. These results show that cocaine and the metabolite BE are not effectively removed during wastewater treatment.

Cotinine

The standard curve for cotinine was developed using the urine standards provided with the Neogen kit. The cotinine standard curve is shown in Figure 9. Although wastewater samples were concentrated 250:1, concentrations were not detected by the Neogen plate. Utah has the lowest percent of cigarette smokers in the nation at 9.3%. The low percentage of smokers and high biodegradability of cotinine likely contribute to undetectable concentrations.

Methamphetamine

Samples for methamphetamine detection were diluted two-fold. Glass fiber filtered samples were run in triplicate and raw samples were run individually. The standard curve for meth, shown in Figure 10, was developed using the 500 $\mu\text{g/L}$ urine cut-off calibrator.

Methamphetamine concentrations in the sewer lines were much higher than the treated effluent. The concentrations range was 86 $\mu\text{g/L}$ to 460 $\mu\text{g/L}$ for the 1.2 μm glass fiber filtered samples. All of the raw samples displayed higher meth concentrations, 308 $\mu\text{g/L}$ to 966 $\mu\text{g/L}$, indicating that the methamphetamine compounds have likely sorbed onto the biosolids. The filtered organic particles would need to be tested to determine if some of the meth compounds were removed by filtration. The trickling filter showed concentrations of 32 $\mu\text{g/L}$ and 54 $\mu\text{g/L}$ for the filtered and unfiltered samples,

respectively. Solids contact showed a higher concentration, 58 $\mu\text{g/L}$ and 64 $\mu\text{g/L}$. There are some chemicals in the wastewater that may be converted into methamphetamine during the solids contacts, such as MDMA. Any MDMA in the wastewater may be converting to meth, thus increasing the concentrations detected by the immuno-assay. The effluent of the filtered sample showed a concentration of 12 $\mu\text{g/L}$, while the unfiltered effluent sample had a concentration of 54 $\mu\text{g/L}$ (Table 6).

Nandrolone

The standard curve for nandrolone was developed using the positive control provided by Neogen. Figure 11 displays the standard curve developed for nandrolone. The wastewater samples for nandrolone were concentrated 25:1, which proved to be too low to detect nandrolone in raw sewage and wastewater.

Oxycodone

The Neogen oxycodone testing kit provided a 100 $\mu\text{g/L}$ urine cut-off calibrator, which was used to develop the standard curve shown in Figure 12.

The samples used for oxycodone detection were concentrated 25:1. Table 7 displays the concentrations found. The concentrations in the sewer lines ranged from 0.04 $\mu\text{g/L}$ to 0.13 $\mu\text{g/L}$. The wastewater treatment showed a decrease in concentration in all three sampling locations: trickling filter (0.08 $\mu\text{g/L}$), solids contact (0.07 $\mu\text{g/L}$), effluent (0.04 $\mu\text{g/L}$).

THC

The THC standard curve was developed using the urine cutoff calibrator supplied in the Neogen Kit (Figure 13).

Samples collected for THC testing were concentrated 25:1. THC concentrations varied in the sewer lines from 0.005 µg/L to 1.42 µg/L, as displayed in Table 8. The concentration from the trickling filter was 0.03 µg/L. There were no detectable traces of THC found in the samples from the solids contact and effluent, indicating that the majority of THC was likely removed during solids contact due to its high biodegradability.

Discussion

The drug test kits for caffeine, cocaine, methamphetamine, oxycodone, and THC detected concentrations that are within the ranges found from the literature review, in Table 2. Although the concentrations were on the lower end of the ranges, it can be assumed that the Neogen kits can be effective at detecting illegal drugs in wastewater. To verify the concentrations found, analysis with another detection method, such as GC-MS or LC-MS/MS, would be beneficial. Drug standards that are regulated by the DEA would be required for chromatographic detection methods, thus, comparisons were not made with this research. After comparing concentrations found using the Neogen kits versus another method, the practicality of using Neogen kits for testing would be determined.

The kits for cotinine and nandrolone did not have low enough detection limits for this analysis. It can be assumed that either the concentrations in the wastewater in Salt

Lake County are low enough to not be of concern at this time or use of immuno-assay is inefficient for detection in wastewater. Utah has the lowest rate of cigarette smokers in the nation, so it may be possible that cotinine levels are just too low for detection.

The highest concentration of samples came from the raw sewage samples from various districts. Table 9 shows that Kearns Improvement District had the highest concentrations of caffeine and cocaine, Taylorsville-Bennion had the highest of methamphetamine, Granger-Hunter was highest for oxycodone and Cottonwood had the highest for THC. Drug statistic data is published per county, not city, so it is difficult to know if these values correlate to true consumption of drugs in each of these areas.

Volumetric flow rates were taken at the time of sampling. These flow rates, used with population of districts, were used to calculate the mass flux per capita. These values (Table 10) can be used with forensic data to obtain more accurate estimates of populations of users. Murray City has the highest mass flux for caffeine, cocaine, and methamphetamine, while Kearns has the highest flux for oxycodone and Cottonwood Heights has the highest flux for THC. It appears that Murray City is a high drug abuse region.

Results also determined that there are losses of drug analytes during glass fiber filtration. Table 11 displays the percent losses of drug analytes due to filtration. The percent loss ranges from 22% to 92%. The total concentration of filtered samples could be verified by collecting the solids from the glass fiber filter and using solid phase extraction, followed by detection using the Neogen kit, GC-MS or LC-MS.

Wastewater treatment processes proved to remove a portion of the drugs in wastewater, as shown in Table 12. The removal rates varied from 43% of cocaine to 100% removal of THC. Cocaine showed an increase in concentrations in the trickling filter and solids contact, rather than removal. The drug test kit used for cocaine detects concentrations of BE more accurately than that of cocaine. It is possible that any cocaine in the wastewater was metabolized during the trickling filter and solids contact, thus showing higher concentrations in the drug detection kits. Samples from more locations within the wastewater treatment plant could be used to verify this hypothesis.

For further research, other types of drugs could be tested in Salt Lake County's wastewater, such as opioids and hallucinogens. Further testing at each process in the wastewater treatment plant, surface waters and groundwater that are impacted by wastewater, and drinking water sources using immune-assays, would further confirm whether it is a sufficient method for illegal drug detection. Immuno-assay detection coupled with chromatographic detection in future experiments will determine the efficiency of immuno-assay concentration detection.

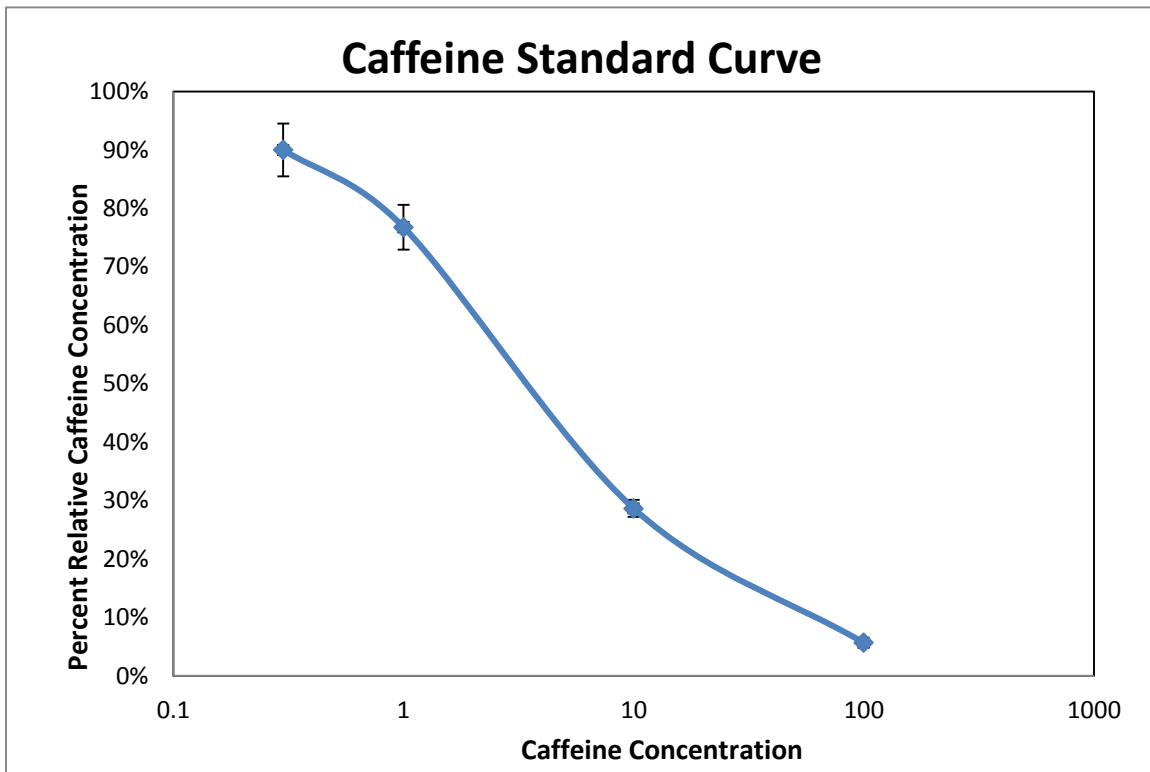

Figure 7 - Caffeine Standard Curve

Table 4 - Caffeine Concentration Results

	Caffeine Concentration from Raw Samples (µg/L)	Caffeine Concentration from Filtered Samples (µg/L)
Cottonwood	194	70 ± 32.22
Granger – Hunter	90	98 ± 24.56
Kearns	192	168 ± 9.96
Murray	124	160 ± 2.50
Mt. Olympus East	160	126 ± 10.74
Mt. Olympus South	124	126 ± 1.28
South Salt Lake	132	118 ± 6.48
Taylorville- Bennion	136	146 ± 2.70
Trickling Filter	3	1 ± 0.59
Solids Contact	2.5	1.5 ± 0.34
Effluent	1	0.5 ± 0.02

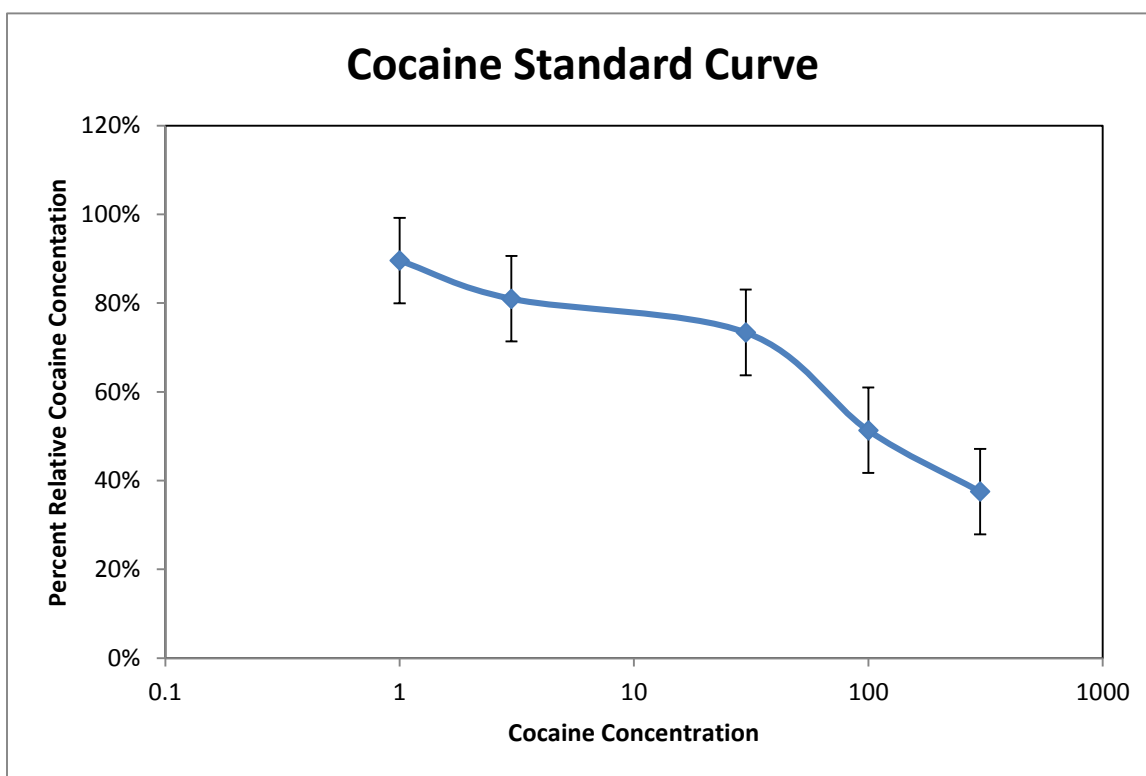

Figure 8 - Cocaine Standard Curve

Table 5 - Cocaine Concentration Results

	Cocaine Concentration from Raw Samples (µg/L)	Cocaine Concentration from Filtered Samples (µg/L)
Cottonwood	42	31 ± 10.51
Granger – Hunter	50	42 ± 11.46
Kearns	73	10 ± 2.19
Murray	45	51 ± 6.05
Mt. Olympus East	63	40 ± 13.66
Mt. Olympus South	48	50 ± 14.30
South Salt Lake	67	45 ± 5.24
Taylorville- Bennion	27	41 ± 3.65
Trickling Filter	65	44 ± 9.36
Solids Contact	40	37 ± 4.43
Effluent	33	20 ± 1.67

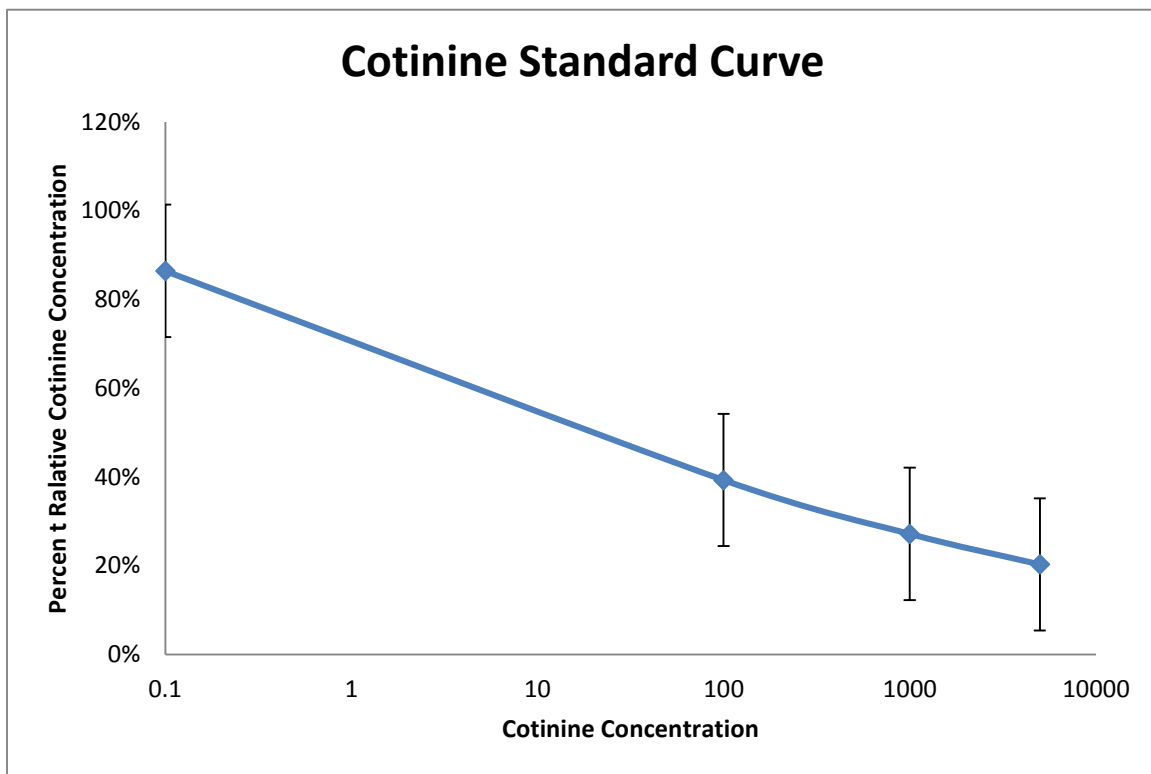

Figure 9 - Cotinine Standard Curve

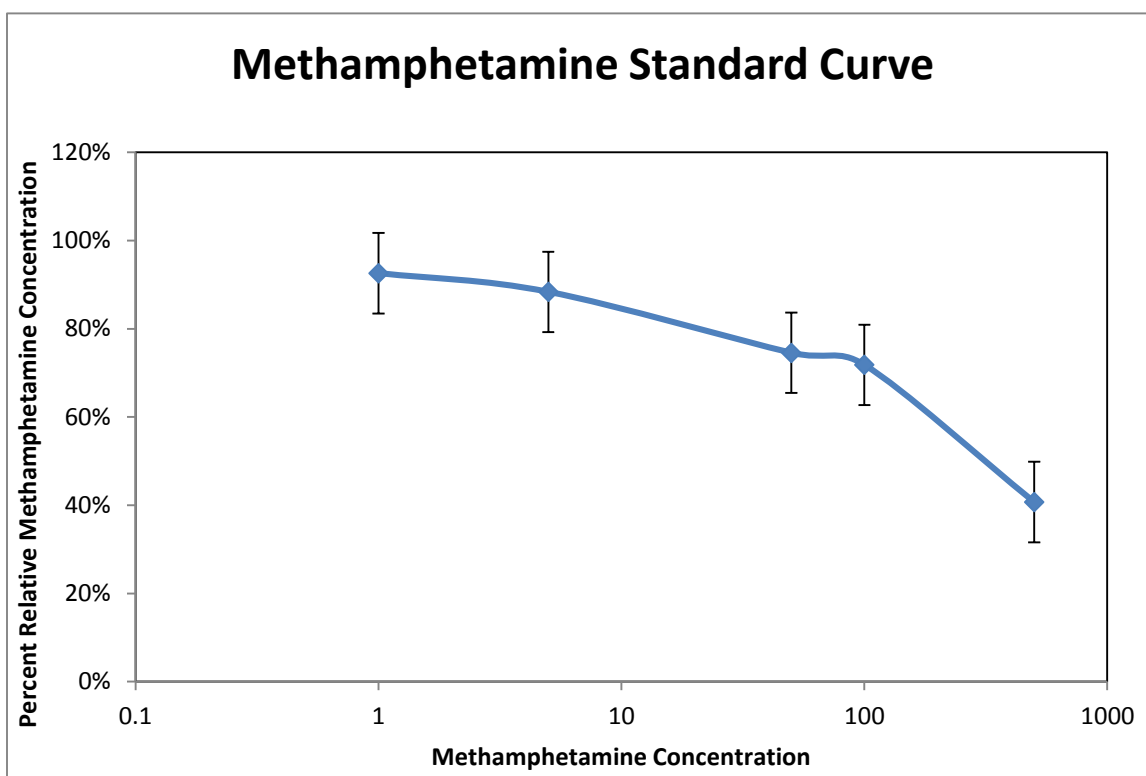

Figure 10 - Methamphetamine Standard Curve

Table 6 - Methamphetamine Concentration Results

	Methamphetamine Concentration from Raw Samples (µg/L)	Methamphetamine Concentration from Filtered Samples (µg/L)
Cottonwood	308	86 ± 11.17
Granger – Hunter	540	372 ± 15.59
Kearns	966	422 ± 39.53
Murray	624	414 ± 42.24
Mt. Olympus East	616	174 ± 17.66
Mt. Olympus South	454	176 ± 4.82
South Salt Lake	588	286 ± 24.79
Taylorville-Bennion	940	460 ± 37.62
Trickling Filter	54	32 ± 0.71
Solids Contact	64	58 ± 4.61
Effluent	54	12 ± 0.36

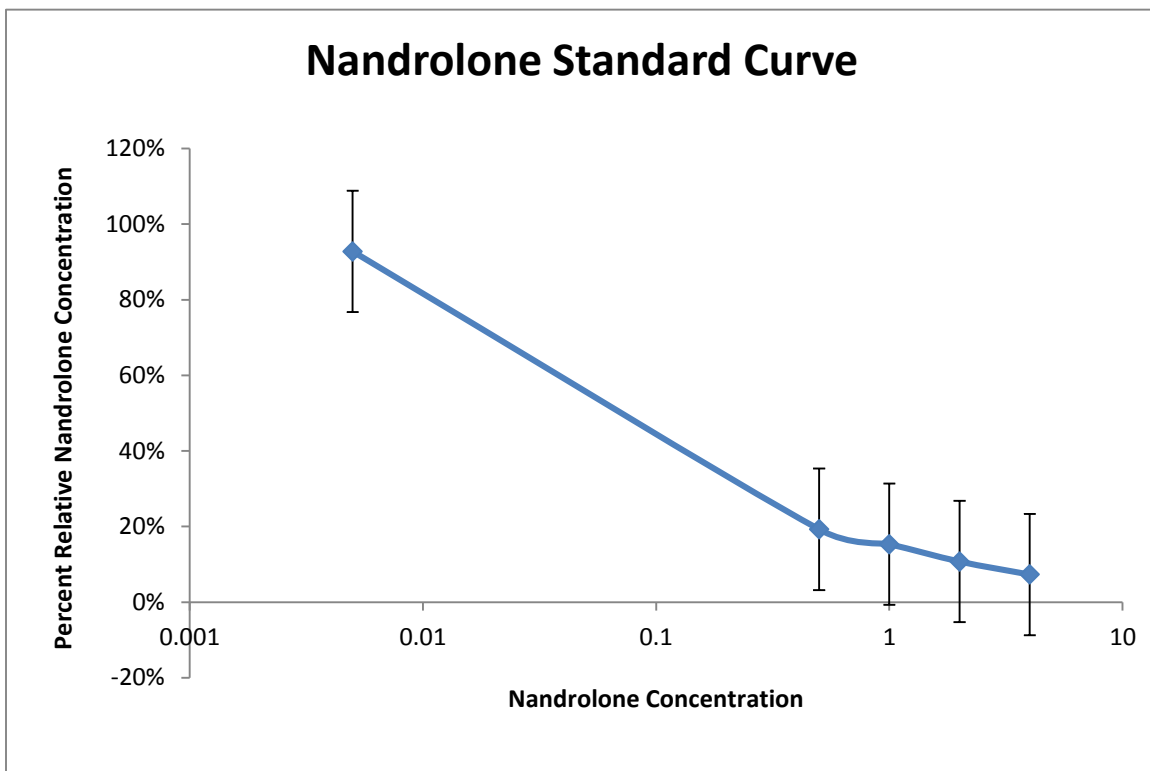

Figure 11 - Nandrolone Standard Curve

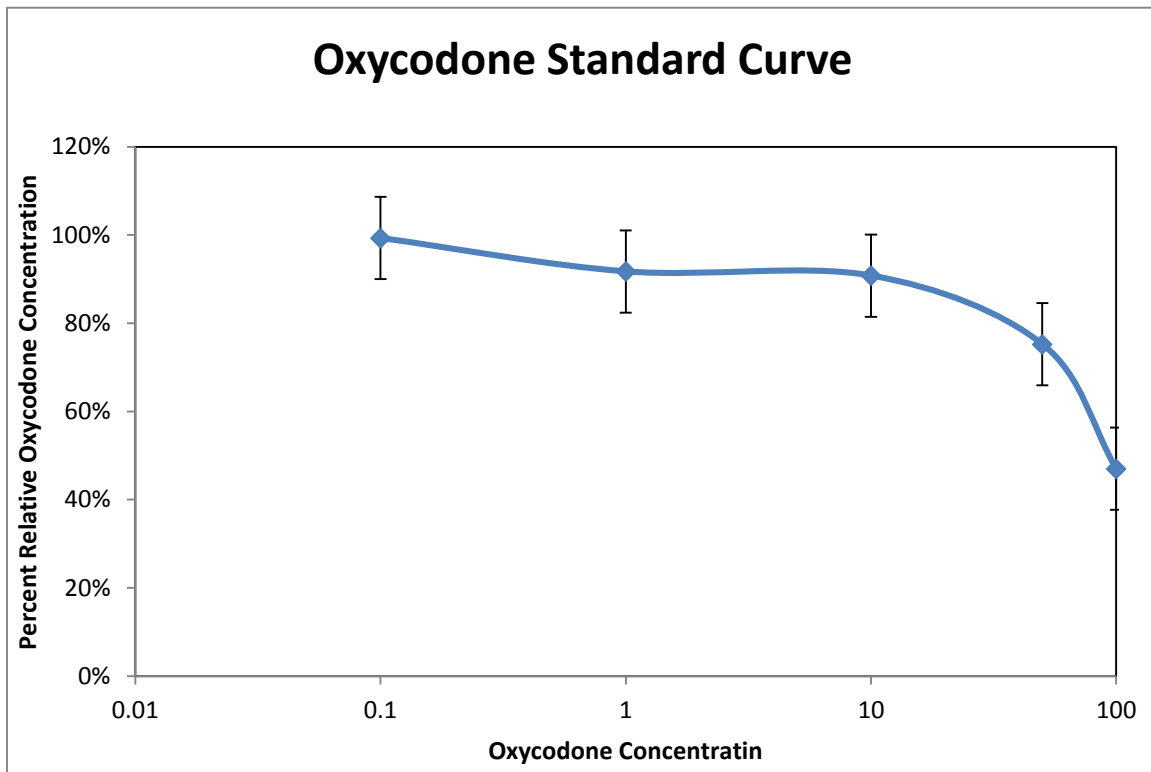

Figure 12 - Oxycodone Standard Curve

Table 7 - Oxycodone Concentration Results

	Oxycodone Concentration from Filtered Samples (µg/L)
Cottonwood	0.11 ± 0.012
Granger – Hunter	0.13 ± 0.010
Kearns	0.13 ± 0.016
Murray	0.10 ± 0.004
Mt. Olympus East	0.04 ± 0.004
Mt. Olympus South	0.08 ± 0.010
South Salt Lake	0.09 ± 0.012
Taylorville-Bennion	0.04 ± 0.009
Trickling Filter	0.08 ± 0.010
Solids Contact	0.07 ± 0.006
Effluent	0.04 ± 0.009

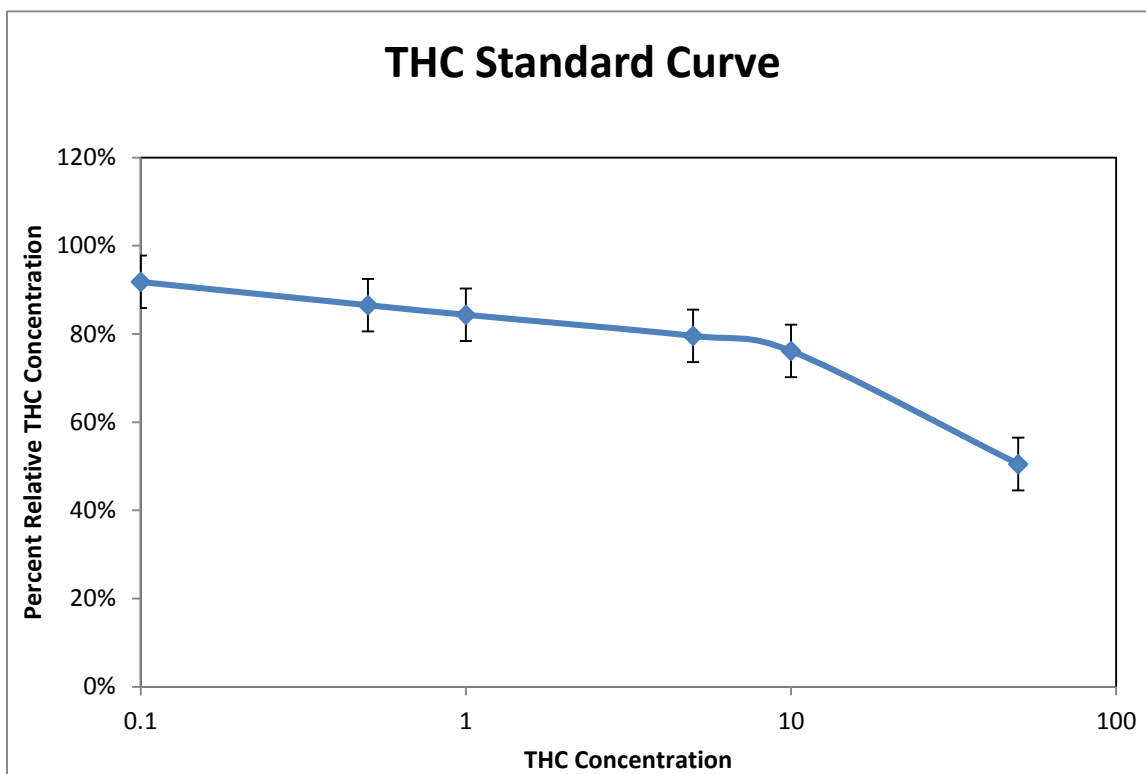

Figure 13 - THC Standard Curve

Table 8 - THC Concentration Results

	THC Concentration (µg/L)
Cottonwood	1.42 ± 0.294
Granger – Hunter	0.68 ± 0.052
Kearns	0.92 ± 0.120
Murray	0.32 ± 0.045
Mt. Olympus East	0.38 ± 0.069
Mt. Olympus South	0.78 ± 0.202
South Salt Lake	0.03 ± 0.042
Taylorville-Bennion	0.005 ± 0.015
Trickling Filter	0.03 ± 0.014
Solids Contact	0.0 ± 0.006
Effluent	0.0 ± 0.017

Table 9 - Average, Maximum and Minimum Concentrations in Sewer Lines

NA indicates that raw samples were not tested for detection of that particular drug.

Drug	Average Raw Concentration (µg/L)	Average Filtered Concentration (µg/L)	Maximum Concentration (µg/L)	Minimum Concentration (µg/L)
Caffeine	144	127	168 - Kearns	70 – Cottonwood
Cocaine	52	35	51 – Kearns	1 – Cottonwood
Cotinine	NA	ND	ND	ND
Methamphetamine	630	299	460 – Taylorsville - Bennion	86 – Cottonwood
Nandrolone	NA	ND	ND	ND
Oxycodone	NA	0.09	0.134 – Granger	0.041 – Taylorsville
THC	NA	0.57	1.42 - Cottonwood	0.005 – Taylorsville

Table 10 - Mass Flux per Capita

	Population	Flow Rate (MGD)	Mass Flux Per Capita (µg / person – day)				
			Caffeine	Cocaine	Meth	Oxycodone	THC
Cottonwood Heights	129000	12.78	26165	378	32145	41	531
Granger-Hunter	120000	36.72	29987	12852	113827	40	208
Kearns	40000	15.90	66775	3975	175681	52	366
Mt. Olympus (Combined)		49.32					
Murray City	46000	21.88	75610	24100	195641	47	151
South Salt Lake City	24000	12.04	59145	22555	143353	45	15
Taylorsville-Bennion	70000	22.37	46661	13103	147015	13	1.6

Table 11 - Percent Loss of Analytes due to Filtration

% Loss in Drug from Filtering vs. Raw Samples			
	Caffeine	Cocaine	Methamphetamine
Average for Sewer Lines	87.8%	67.5%	47.5%
Trickling Filter	33.3%	67.7%	59.3%
Solids Contact	60.0%	92.5%	90.6%
Effluent	50.0%	60.6%	22.2%

Table 12 - Percent Removal from Wastewater Treatment
(Cotinine and Nandrolone were not detected)

	% From Trickling Filter	% From Solids Contact	% Total Removal
Caffeine	99.2%	98.8%	99.2%
Cocaine	-25.7%	-5.7%	42.9%
Cotinine	-	-	-
Methamphetamine	89.3%	80.6%	96.0%
Nandrolone	-	-	-
Oxycodone	11.1%	22.2%	55.6%
THC	94.7%	100%	100%

CHAPTER 5

CONCLUSION

This study proved that the use of immuno-assays could be used to detect some illegal and recreational drugs of abuse in wastewater in a timely and cost effective manner. Cotinine and nandrolone analytes were not detected by the ELISA kits. The five remaining drugs tested were all detected within the limits of the Neogen ELISA kits used. Caffeine, methamphetamine, and THC showed a high percentage of removal (99.2% - 100%) through the wastewater treatment process. Cocaine showed a 42.9% removal and oxycodone showed a 55.6% removal during treatment.

To improve the studies on the use of immuno-assays for illegal drug detection in wastewater, ELISA tests should be performed with GC or LC methods to confirm detection accuracy. The biosolids removed during filtration with glass fiber filters could also be tested for illegal drugs to determine an accurate percentage of analytes lost during filtration. To determine more precise removal rates, activated sludge samples could also be tested. To further research, the effluent and water body of discharge, the Jordan River, could also be detected for the illegal drugs to determine the removal rates by environmental factors.

Final Remarks

The EPA has not put into place discharge limits on drugs of abuse. Illegal drug usage rates are continually rising and the effects on the environment are unknown. European countries have begun tests to determine the impacts, but there is little research effort in the United States. This may be due to DEA restrictions, or costs of detection methods. As more societies begin using reclaimed water as a drinking water source, illegal drug concentrations will become an even larger concern. When the EPA begins enforcing discharge concentrations, wastewater facilities will need to incorporate new detection and treatment methods. Immuno-assays may be a cost and time effective method to begin detection.

APPENDIX

METHOD DEVELOPMENT DETAILS

Glass Fiber Filtering

1. 1.2 μm glass fiber filters are recommended.
2. Rinse filtering flask, glass frit, and filter funnel with millique water.
3. Pass 100mL of millique water through assembled filter holder.
4. Add glass fiber filter to assembly and rinse filter with 100 mL of millique water.
5. Filter sample.
6. Collect filtrate for testing and for C-18 processing.

C-18 Concentration

1. Rinse all glassware with millique water followed by ethanol.
2. Assemble filter holder and pass ethanol through glass frit.
3. Reassemble with C-18 membrane in place.
4. Soak for 1 minute in 20% ethanol, apply vacuum, and pull through.
5. Repeat with 60% ethanol and 100% ethanol.
6. Add 15 mL ethanol and soak for 1 minute. Do not allow disk to run dry at this point.

7. Pull ethanol through until 2-3 mm above membrane surface.
8. Add 15 mL Nanopure water. Pull through until 2-3 mm above membrane surface.
9. Add 500 mL of sample to be concentrated. Do not allow disk to run dry until entire volume has been extracted.
10. Transfer filter assembly to smaller vacuum flask.
11. Add 10 mL ethanol, soak for 1 minute. Pull through. Repeat.
12. Transfer sample to 40 mL (muffled) vial. Dry under N₂.
13. Re-suspend with provided buffer solution in ELISA kits.⁴⁸

Caffeine Test Procedures

1. Filter sample with 1.2 µm glass fiber filter.
2. Dilute sample two-fold using EIA Buffer solution provided with Neogen Caffeine/ Pentoxifylline Detection Kit.
3. Use the instructions included with the Neogen Caffeine/Pentoxifylline Detection Kit with some alterations as shown in test procedure steps a through l listed below:
 - a) Determine the number of wells to be used.

- b) Prepare the enzyme conjugate by diluting the 180X enzyme conjugate stock 1 to 180 in the EIA buffer provided. Mix the solution by inversion. Do not vortex.
- c) Add 20 μL of sample, laboratory calibrators, and Neogen controls to the appropriate wells in triplicate. DO NOT dilute Neogen's positive and negative controls.
- d) Add 180 μL of diluted drug-enzyme conjugate to each well. Use 8-channel pipetter for rapid addition.
- e) Mix by gently shaking plate.
- f) Cover plate with plate cover and incubate at room temperature for 45 minutes.
- g) During conjugation period, dilute concentrated wash buffer ten-fold with deionized water. Mix thoroughly.
- h) Once incubation is complete, dump the liquid from the wells. Tap the plate on a clean lint-free towel to remove any remaining liquid in the wells.
- i) Wash each well with 300 μL of diluted wash buffer. Repeat for a total of three washings, invert and tap dry the plate following each step. After completing the last step wipe the bottom of the wells with a lint-free towel to remove any liquid on the outside of the wells.
- j) Add 150 μL of the K-Blue Substrate to each well.
- k) Incubate at room temperature for 30 minutes.

- l) Add 50 μL of Neogen's Red Stop Solution to each well to stop enzyme reaction. Mix gently before measuring absorbance. Measure the absorbance at a wavelength of 630 nm. Wells should be read within 2 hours of stopping reaction.

Cocaine/ Benzoyllecgonine Test Procedures

1. Filter sample with 1.2 μm glass fiber filter (Do not dilute sample for cocaine tests).
2. Use the instructions included with the Neogen Cocaine/ Benzoyllecgonine Detection Kit with some alterations as shown in test procedure steps a through k listed below:
 - a) Determine the number of wells to be used.
 - b) Gently mix the ready to use conjugate solution by inversion. Do not vortex.
 - c) Add 10 μL of sample, Neogen calibrators to the appropriate wells in triplicate.
 - d) Add 180 μL of ready to use drug-enzyme conjugate to each well. Use 8-channel pipetter for rapid addition.
 - e) Mix by gently shaking plate.
 - f) Cover plate with plate cover and incubate at room temperature for 45 minutes.
 - g) During conjugation period, dilute concentrated wash buffer ten-fold with deionized water. Mix thoroughly.

- h) Once incubation is complete, dump the liquid from the wells. Tap the plate on a clean lint-free towel to remove any remaining liquid in the wells.
- i) Wash each well with 300 μ L of diluted wash buffer. Repeat for a total of three washings, invert and tap dry the plate following each step. After completing the last step wipe the bottom of the wells with a lint-free towel to remove any liquid on the outside of the wells.
- j) Add 100 μ L of the K-Blue Substrate to each well.
- k) Incubate at room temperature for 30 minutes.
- l) Add 100 μ L of Acid Stop (1N H₂SO₄) to each well to stop enzyme reaction. Mix gently before measuring absorbance. Measure the absorbance at a wavelength of 450 nm. Wells should be read within 2 hours of stopping reaction.

Cotinine Test Procedures

1. Filter sample with 1.2 μ m glass fiber filter.
2. Perform C-18 Concentration to obtain a 250:1 concentrated ratio, re-suspended in provided dilution buffer.
3. Use the instructions included with the Neogen Cotinine Detection Kit with some alterations as shown in test procedure steps a through k listed below:
 - a) Allow at least 60 minutes for all test kit components and samples to reach room temperature (20-23°C).

- b) Prior to using a new kit, prepare fully diluted enzyme by adding exactly 150 μL of cotinine enzyme conjugate to the enzyme diluent. Gently invert 15 times.
- c) Determine the number of wells to be used.
- d) Pipette 20 μL of sample and standards into wells in triplicate.
- e) Add 100 μL of prepared cotinine enzyme conjugate to each well. Invert the conjugate several times before adding to wells.
- f) Cover plate with plate cover and incubate at room temperature for 30 minutes. Tap side of plate 3 to 4 times throughout incubation.
- g) Dump the solution from the wells and tamp onto lint free towel. Add 350 μL of deionized water to each well. Dump the deionized water and tamp plate again lint free towel. Repeat the wash step two more times.
- h) Without allowing the wells to dry out, add 100 μL of K-Blue Substrate to each well.
- i) Incubate at room temperature for 30 minutes, tapping sides of the plate 3 to 4 times throughout incubation.
- j) Add 100 μL of Stop Solution to each well to stop enzyme reaction. Mix gently before measuring absorbance.
- k) Measure the absorbance at a wavelength of 450 nm. Wells should be read within 2 hours of stopping reaction.

Methamphetamine/ MDMA Test Procedures

1. Filter sample with 1.2 μm glass fiber filter.

2. Dilute sample two-fold using EIA Buffer solution provided with Neogen Methamphetamine/ MDMA Detection Kit.
3. Use the instructions included with the Neogen Methamphetamine/ MDMA Detection Kit with some alterations as shown in test procedure steps a through l listed below:
 - a) Determine the number of wells to be used.
 - b) Gently mix the ready to use conjugate solution by inversion. Do not vortex.
 - c) Add 10 μL of sample, Neogen calibrators to the appropriate wells in triplicate.
 - d) Add 100 μL of ready to use drug-enzyme conjugate to each well. Use 8-channel pipetter for rapid addition.
 - e) Mix by gently shaking plate.
 - f) Cover plate with plate cover and incubate at room temperature for 45 minutes.
 - g) During conjugation period, dilute concentrated wash buffer ten-fold with deionized water. Mix thoroughly.
 - h) Once incubation is complete, dump the liquid from the wells. Tap the plate on a clean lint-free towel to remove any remaining liquid in the wells.
 - i) Wash each well with 300 μL of diluted wash buffer. Repeat for a total of three washings, invert and tap dry the plate following each step. After

completing the last step wipe the bottom of the wells with a lint-free towel to remove any liquid on the outside of the wells.

- j) Add 100 μ L of the K-Blue Substrate to each well.
- k) Incubate at room temperature for 30 minutes.
- l) Add 100 μ L of Acid Stop (1N H₂SO₄) to each well to stop enzyme reaction. Mix gently before measuring absorbance. Measure the absorbance at a wavelength of 450 nm. Wells should be read within 2 hours of stopping reaction.

Nandrolone Test Procedures

1. Filter sample with 1.2 μ m glass fiber filter.
2. Perform C-18 Concentration to obtain a 25:1 concentrated ratio, re-suspended in provided EIA Buffer.
3. Use the instructions included with the Neogen Nandrolone Detection Kit with some alterations as shown in test procedure steps a through n listed below:
 - a) Allow at least 60 minutes for all test kit components and samples to reach room temperature (20-23°C).
 - b) Determine the number of wells to be used.
 - c) Prepare the enzyme conjugate by diluting the 180X enzyme conjugate stock 1 to 180 in the EIA Buffer provided. Mix the solution by inversion.
 - d) Add 20 μ L of sample and standards into wells in triplicate.
 - e) Add 180 μ L of diluted enzyme conjugate to each well.
 - f) Mix gently by shaking plate.

- g) Cover plate with plate cover and incubate at room temperature for 60 minutes.
- h) During conjugation period, dilute concentrated wash buffer ten-fold with deionized water. Mix thoroughly.
- i) Dump the solution from the wells and tap onto lint free towel.
- j) Wash each well with 300 μL of diluted wash buffer. Repeat for a total of three washings, invert and tap dry the plate following each step. After completing the last step wipe the bottom of the wells with a lint-free towel to remove any liquid on the outside of the wells.
- k) Add 150 μL of K-Blue Substrate to each well.
- l) Incubate at room temperature for 30 minutes, tapping sides of the plate three to four times throughout incubation.
- m) Add 50 μL of Neogen's Red Stop Solution to each well to stop enzyme reaction. Mix gently before measuring absorbance.
- n) Measure the absorbance at a wavelength of 630 nm. Wells should be read within 2 hours of stopping reaction.

Oxycodone/ Oxymorphone Test Procedures

1. Filter sample with 1.2 μm glass fiber filter.
2. Perform C-18 Concentration to obtain a 25:1 concentrated ratio, re-suspended in provided EIA Buffer Solution provided.

3. Use the instructions included with the Neogen Oxycodone/ Oxymorphone Detection Kit with some alterations as shown in test procedure steps a through l listed below:
 - a) Determine the number of wells to be used.
 - b) Gently mix the ready to use conjugate solution by inversion. Do not vortex.
 - c) Add 10 μL of sample, Neogen calibrators to the appropriate wells in triplicate.
 - d) Add 100 μL of ready to use drug-enzyme conjugate to each well. Use 8-channel pipetter for rapid addition.
 - e) Mix by gently shaking plate.
 - f) Cover plate with plate cover and incubate at room temperature for 45 minutes.
 - g) During conjugation period, dilute concentrated wash buffer ten-fold with deionized water. Mix thoroughly.
 - h) Once incubation is complete, dump the liquid from the wells. Tap the plate on a clean lint-free towel to remove any remaining liquid in the wells.
 - i) Wash each well with 300 μL of diluted wash buffer. Repeat for a total of three washings, invert and tap dry the plate following each step. After completing the last step wipe the bottom of the wells with a lint-free towel to remove any liquid on the outside of the wells.
 - j) Add 100 μL of the K-Blue Substrate to each well.

- k) Incubate at room temperature for 30 minutes.
- l) Add 100 μ L of Acid Stop (1N H₂SO₄) to each well to stop enzyme reaction. Mix gently before measuring absorbance. Measure the absorbance at a wavelength of 450 nm. Wells should be read within 2 hours of stopping reaction.

THC Test Procedures

1. Filter sample with 1.2 μ m glass fiber filter.
2. Perform C-18 Concentration to obtain a 25:1 concentrated ratio, re-suspended in provided EIA Buffer Solution provided.
3. Use the instructions included with the Neogen THC Detection Kit with some alterations as shown in test procedure steps a through l listed below:
 - a) Determine the number of wells to be used.
 - b) Gently mix the ready to use conjugate solution by inversion. Do not vortex.
 - c) Add 10 μ L of sample, Neogen calibrators to the appropriate wells in triplicate.
 - d) Add 100 μ L of ready to use drug-enzyme conjugate to each well. Use 8-channel pipetter for rapid addition.
 - e) Mix by gently shaking plate.
 - f) Cover plate with plate cover and incubate at room temperature for 45 minutes.

- g) During conjugation period, dilute concentrated wash buffer ten-fold with deionized water. Mix thoroughly.
- h) Once incubation is complete, dump the liquid from the wells. Tap the plate on a clean lint-free towel to remove any remaining liquid in the wells.
- i) Wash each well with 300 μL of diluted wash buffer. Repeat for a total of three washings, invert and tap dry the plate following each step. After completing the last step wipe the bottom of the wells with a lint-free towel to remove any liquid on the outside of the wells.
- j) Add 100 μL of the K-Blue Substrate to each well.
- k) Incubate at room temperature for 30 minutes.
- l) Add 100 μL of Acid Stop (1N H_2SO_4) to each well to stop enzyme reaction. Mix gently before measuring absorbance. Measure the absorbance at a wavelength of 450 nm. Wells should be read within 2 hours of stopping reaction.

REFERENCES

1. Rannazzisi, J. T.; Caverly, M. W. *Practitioner's Manual: An Informational Outline of Controlled Substances Act. United States Department of Justice: Drug Enforcement Administration: Office of Diversion of Control: Springfield, VA, 2006.*
2. Thomas, K. V. et al. Comparing Illicit Drug Use in 19 European Cities through Sewage Analysis. *Science of the Total Environment.* **2012**, *432*, 432-439.
3. Knight, C. A.; Knight, I.; Michel, D. C.; Zepp, J. E. Beverage Caffeine Intake in US Consumers and Subpopulations of Interest: Estimates from the Share of Intake Panel Survey. *Food and Chemical Toxicology.* **2004**, *42*, 1923-1930.
4. Birkett, D. J.; Miners, J. O. Caffeine Renal Clearance and Urine Caffeine Concentrations during Steady State Dosing. Implications for Monitoring Caffeine Intake during Sports Events. *British Journal of Clinical Pharmacology.* **1991**, *31*, 401-408.
5. Buerge, I. J.; Poiger, T.; Muller, M. D.; Buser, H. Caffeine, an Anthropogenic Marker for Wastewater Contamination of Surface Waters. *Environmental Science Technology.* **2003**, *37*, 691-700
6. WebMD, LCC. Find a Vitamin or Supplement: Caffeine.
<http://www.webmd.com/vitamins-supplements/ingredientmono-979-CAFFEINE.aspx?activeIngredientId=979&activeIngredientName=CAFFEINE>
(accessed Aug 21, 2012).
7. Rodriguez del Rey, Z.; Granek, E. F.; Buckley, B. A. Expression of HSP70 in *Mytilus Californianus* Following Exposure to Caffeine. *Ecotoxicology.* **2011**, *20*, 855-861.
8. International Program on Chemical Safety (INCHEM). Chemical Safety Information from Intergovernmental Organizations. <http://www.inchem.org/> (accessed Dec 5, 2012).

9. TEVA Pharmaceuticals USA Inc. Oxycodone Hydrochloride.
<http://dailymed.nlm.nih.gov/dailymed/lookup.cfm?setid=2d044a8e-8fdb-4299-a3facd8761d9ad58> (accessed Nov 21, 2012).
10. Sui, Q.; Huang, J.; Deng, S.; Yu, G.; Fan, Q. Occurrence and Removal of Pharmaceuticals, Caffeine and DEET in Wastewater Treatment Plants of Beijing, China. *Water Research*. **2010**, *44*, 417-426.
11. WebMD, LCC. Mental Health Center: Cocaine Use and Its Effects.
<http://www.webmd.com/mental-health/cocaine-use-and-its-effects> (accessed Aug 21, 2012).
12. Sangster, James. Octanol-Water Partition Coefficients of Simple Organic Compounds. *Journal of Physical and Chemical Reference Data*. **1989**, *18*, 1111-1227.
13. National Center for Biotechnology Information, U.S. National Library of Medicine (NCBI). The PubChem Project. <http://pubchem.ncbi.nlm.nih.gov/> (accessed Sept 18, 2012).
14. University of California, San Francisco (UCSF). Lifecycle of Cotinine.
<http://www.teensmokingstudy.com/cotinine.html> (accessed Aug 21, 2012)
15. Drugs.com: Drug Information Online. Nicotine Side Effects.
<http://www.drugs.com/sfx/nicotine-side-effects.html> (accessed Nov 25, 2012).
16. Bones, J.; Thomas K. V.; Paull, B. Using Environmental Analytical Data to Estimate Levels of Community Consumption of Illicit Drugs and Abused Pharmaceuticals. *Supplementary Material (ESI) for Journal of Environmental Monitoring*. **2007**, *7*, 701-701.
17. Frontline, WGBH Educational Foundation. The Meth Epidemic: How Meth Destroys the Body. <http://www.pbs.org/wgbh/pages/frontline/meth/body/> (accessed Aug 8, 2012).
18. National Institute on Drug Abuse: The Science of Drug Abuse & Addiction. DrugFacts: MDMA (Ecstasy).
<http://www.drugabuse.gov/publications/drugfacts/mdma-ecstasy> (accessed July 7, 2012).
19. Drugs.com: Drug Information Online. Nandrolone Side Effects.
<http://www.drugs.com/sfx/nandrolone-side-effects.html> (accessed Nov 25, 2012).

20. May, P. School of Chemistry, University of Bristol. Molecule of the Month-October 2000: Nandrolone. <http://www.chm.bris.ac.uk/motm/nandrolone/nandh.htm> (accessed Sept 18, 2012).
21. Lange, I. G.; Daxenberger, A.; Schiffer, B.; Writters, H.; Ibarreta, D.; Meyer, H. H. Sex Hormones Originating from Different Livestock Production Systems: Fate and Potential Disrupting Activity in the Environment. *Analytica Chimica Acta*, **2002**, *473*, 27-37.
22. Drugs.com: Drug Information Online. Oxycodone Side Effects. <http://www.drugs.com/sfx/oxycodone-side-effects.html> (accessed Nov 25, 2012)
23. National Institute on Drug Abuse: The Science of Drug Abuse & Addiction. DrugFacts: Marijuana. <http://www.drugabuse.gov/publications/drugfacts/marijuana> (accessed July 7, 2012).
24. Swartz, M. E. Ultra Performance Liquid Chromatography (UPLC): An Introduction. *Separation Science Redefined* [Online] **2005**, p 8-14. Chromatography Online. <http://www.chromatographyonline.com/lcgc/data/articlestandard/lcgc/242005/164646/article.pdf> (accessed Nov 21, 2012).
25. Verstraete, A. G. Detection Times of Drugs of Abuse in Blood, Urine, and Oral Fluid. *The Drug Monit.* **2004**, *26*, 200-2005.
26. *Utah Drug Control Update: 2010*; Office of National Drug Control Policy Programs. Salt Lake City, UT, 2010.
27. *Division of Substance Abuse and Mental Health 2009 Annual Report*; Department of Human Services; Department of Human Services: Salt Lake City Utah, 2009.
28. Castiglioni, S.; Zuccato, E.; Fanelli R. *Illicit Drugs in the Environment; Occurrence, Analysis and Fate Using Mass Spectrometry*; John Wiley & Sons, Inc. New Jersey, pp 251-274.
29. Walters Jr. K. R.; Rupassara, S. I.; Marketz, R. C.; Leakey, A. D.; Muir, W. M.; Pittendrigh, B. R. Methamphetamine Causes Anorexia in *Drosophila Melanogaster*, Exhausting Metabolic Reserves and Contributing to Mortality. *The Journal of Toxicological Science.* **2012**, *37*, 773-790.
30. Library 4 Science: Chromatography-Online.org. Liquid Chromatography. <http://www.chromatographyonline.org/4/contents.html> (accessed Dec 14, 2012).

31. Doucette, W. J. Octanol/water Partition Coefficient. Presented at Introduction to Environmental Organic Chemistry, Utah State University, Logan, UT, November 2012.
32. Dyke, T. M.; Sams, R.A. Detection and Determination of Theobromine and Caffeine in Urine after Administration of Chocolate-Coated Peanuts to Horses. *Journal of Analytical Toxicology*. **1998**, *22*, 112-116.
33. ChemGuide. High Performance Liquid Chromatography-HPLC.
<http://www.chemguide.co.uk/analysis/chromatography/hplc.html> (accessed Dec 14, 2012).
34. U.S. Department of Justice: Drug Enforcement Administration; Office of Diversion Control. Controlled Substances Schedules.
<http://www.deadiversion.usdoj.gov/schedules/index.html#define> (accessed Dec 03, 2012).
35. Kasprzyk-Hordern, B.; Dinsdale, R. M.; Guwy, A. J. The Removal of Pharmaceuticals, Personal Care Products, Endocrine Disruptors and Illicit Drugs during Wastewater Treatment and its Impact on the Quality of Receiving Waters. *Water Research*. **2009**, *43*, 363-380.
36. Zuccato, E.; Castiglioni, S. Illicit Drugs in the Environment. *Philosophical Transactions of the Royal Society A*. **2009**, *367*, 3965-3978.
37. Valcarcel, Y. et al. Drugs of Abuse in Surface and Tap Waters of the Tagus River Basin: Heterogeneous Photo-Fenton Process is Effective in their Degradation. *Environment International*. **2012**, *41*, 35-43.
38. Jurado, A.; Mastroianni, N.; Vazquez-Sune, E.; Carrera, J.; Tubau, I.; Pujades, E.; Postigo, C.; Lopez de Alda, M.; Barcelo, D. Drugs of Abuse in Urban Groundwater. A case study: Barcelona. *Sciences of the Total Environment*. **2012**, *424*, 280-288.
39. Utah Department of Human Services. Substance Abuse and Mental Health.
<http://www.dsamh.utah.gov/substanceabusetreatment.htm> (accessed Nov 25, 2012).
40. Zuccato, E.; Chiabranod, C.; Castiglioni, S.; Bagnati, R.; Fanelli, R. Estimating Community Drug Abuse by Wastewater Analysis. *Environmental Health Perspective*. **2008**, *116.8*, 1027-1032.

41. Chiaia A. C.; Banta-Green, C.; Field, J. Eliminating Solid Phase Extraction with Large Volume LC/MS/MS: Analysis of Illicit and Legal Drugs and Human Urine Indicators in US Wastewaters. *Environmental Science Technology*. **2008**, *42*(23), 8841-8848.
42. Boleda R. M.; Galceran M. T.; Ventura F. Trace Determination of Cannabinoids and Opiates in Wastewater and Surface Waters by Ultra-Performance Liquid Chromatography-Tandem Mass Spectrometry. *Journal of Chromatography A*. **2007**, *1175*, 38-48.
43. Central Valley Water Reclamation Facility: A Natural Solution.
<http://www.cvwrf.org/brochure/page2.php> (accessed June 28, 2012).
44. Utah Water Science Center. U.S. Geological Survey, West Valley, UT. Personal communication, 2012.
45. Neogen Corporation. Neogen Toxicology: ELISA Assay Principal.
http://www.neogen.com/Toxicology/Assay_Principle.html (accessed May 5, 2012).
46. University of California, Davis (UC-Davis). Instrumental Analysis: Chromatography.
http://chemwiki.ucdavis.edu/Analytical_Chemistry/Instrumental_Analysis/Chromatography (accessed Dec 14, 2012).
47. University of California, Los Angeles (UCLA). Gas Chromatography.
<http://www.chem.ucla.edu/~bacher/General/30BL/gc/theory.html> (accessed Nov 1, 2012).
48. Conroy, O. Estrogenic and Anti-estrogenic Activity Present in Wastewater Effluent and Reclaimed Water. Ph.D. Dissertation, University of Arizona, Tucson, AZ, 2006.